



24VDC Input Module

HE350DIM610

Positive / Negative Logic

16 Channels

SmartStix

For electronic information, see www.SmartStix.com.

This product has a Programming Reference (SUP0552).

1 SPECIFICATIONS

Specifications			
Number of input points	16	OFF to ON Response	0 - 3ms. or less
Rated Input Current	7mA	ON to OFF Response	0 - 3ms. or less
ON Voltage Level	19VDC or more	Common Terminal	16 points / COM
OFF Voltage Level	6VDC or less	Operating Indicator	LED turns on during ON state of input
Input Characteristics	Bidirectional	External Connections	Terminal block connector (M3 x 6 screws)
Isolation Method	Photo Coupler	Altitude for use	Up to 2,000m
General			
Storage Temperature	-25° to 70° C	Pollution degree	2 or lower
Operating Temperature	0° to 55° C	Internal power Consumption (mA)	200mA
Atmosphere	Free from corrosive gases and excessive dust	Cooling method	Self-cooling
Operating and Storage Humidity	5 to 95% Non-condensing	Weight	5.5 oz. (157 g)
Vibration			
Occasional Vibration			
Frequency	Acceleration	Amplitude	Sweep Count
10 ≤ f < 57 Hz	-	0.075 mm	10 times in each direction for X, Y, Z
57 ≤ f ≤ 150 Hz	9.8 m/s ² {1G}	-	
Continuous Vibration			
Frequency	Acceleration	Amplitude	Sweep Count
10 ≤ f < 57 Hz	-	0.035 mm	10 times in each direction for X, Y, Z
57 ≤ f ≤ 150 Hz	4.9 m/s ² {0.5G}	-	
Shocks			
Maximum shock acceleration	147 m/s ² {15G}		
Duration Time	11 ms.		
Pulse Wave	Half sine wave pulse (3 times in each of X, Y, Z directions)		

Specifications continued				
Noise Immunity				
Square wave impulse noise	AC: ± 1,500VDC DC: ± 900VDC			
Electrostatic Discharge	Voltage: 4kV (contact discharge)			
Radiated electromagnetic field	27 – 500MHz, 10V/m			
Fast Transient Burst Noise	Severity level	All power modules	Digital I/Os (Ue ≥24V)	Digital I/Os (Ue < 24 V) Analog I/Os Communication I/Os
	Voltage	2 kV	1 kV	0.25 kV

2 DIMENSIONS

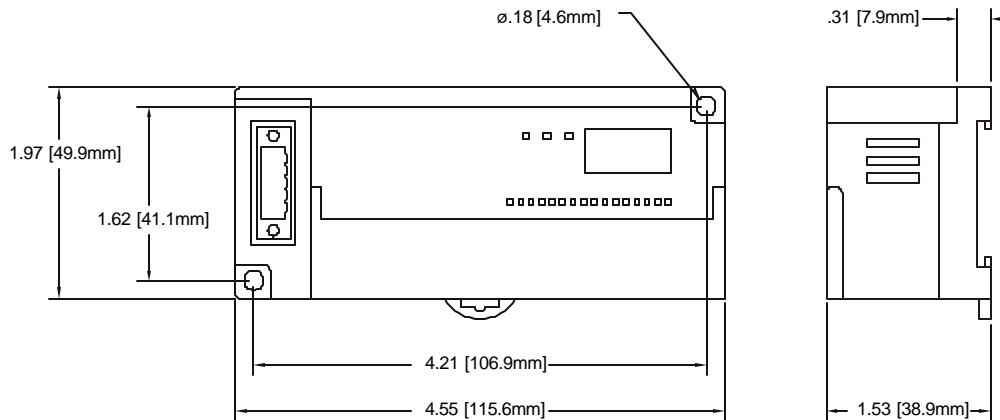

006ACC001

3 WIRING

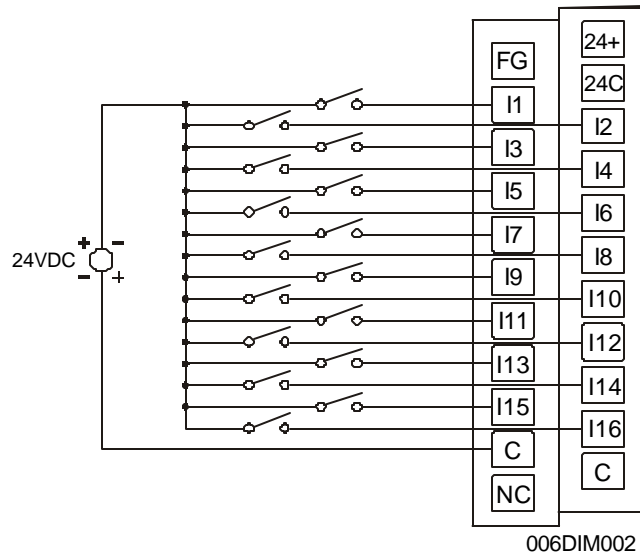

Pin	Signal
	DIM610
24+	24V Power Supply
24C	Power Supply Return
FG	Frame Ground
I1	Input 1
I2	Input 2
I3	Input 3
I4	Input 4
I5	Input 5
I6	Input 6
I7	Input 7
I8	Input 8
I9	Input 9
I10	Input 10
I11	Input 11
I12	Input 12
I13	Input 13
I14	Input 14
I15	Input 15
I16	Input 16
C	Common
C	Common
NC	No Connection

4 INTERNAL WIRING

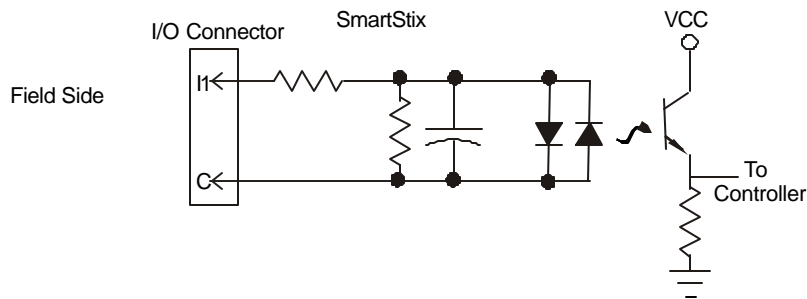

5 SWITCHES

Setting Slave Addresses:

Modbus Slave Addresses are set using the hexadecimal number system from 01 to F7. The decimal equivalent is 1 to 247. Refer to the conversion table in this, which shows the decimal equivalent of hexadecimal numbers. Set a unique address by inserting a small Phillips screwdriver into the two *identical* switches.

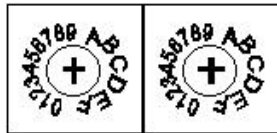
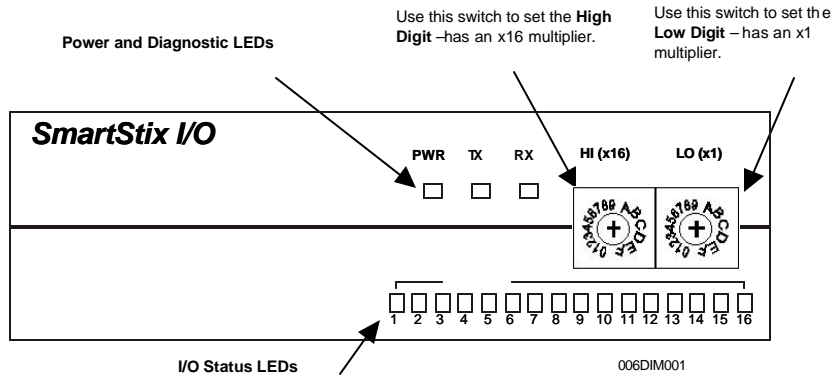

Close-up of Switches

Decimal (Dec) to Hexadecimal (Hex) Conversion																
Dec	Hex		Dec	Hex		Dec	Hex		Dec	Hex	Dec	Hex		Dec	Hex	
	HI	LO		HI	LO		HI	LO				HI	LO		HI	LO
			54	3	6	108	6	C	162	A	2	216	D	8		
1	0	1	55	3	7	109	6	D	163	A	3	217	D	9		
2	0	2	56	3	8	110	6	E	164	A	4	218	D	A		
3	0	3	57	3	9	111	6	F	165	A	5	219	D	B		
4	0	4	58	3	A	112	7	0	166	A	6	220	D	C		
5	0	5	59	3	B	113	7	1	167	A	7	221	D	D		
6	0	6	60	3	C	114	7	2	168	A	8	222	D	E		
7	0	7	61	3	D	115	7	3	169	A	9	223	D	F		
8	0	8	62	3	E	116	7	4	170	A	A	224	E	0		
9	0	9	63	3	F	117	7	5	171	A	B	225	E	1		
10	0	A	64	4	0	118	7	6	172	A	C	226	E	2		
11	0	B	65	4	1	119	7	7	173	A	D	227	E	3		
12	0	C	66	4	2	120	7	8	174	A	E	228	E	4		
13	0	D	67	4	3	121	7	9	175	A	F	229	E	5		
14	0	E	68	4	4	122	7	A	176	B	0	230	E	6		
15	0	F	69	4	5	123	7	B	177	B	1	231	E	7		
16	1	0	70	4	6	124	7	C	178	B	2	232	E	8		
17	1	1	71	4	7	125	7	D	179	B	3	233	E	9		
18	1	2	72	4	8	126	7	E	180	B	4	234	E	A		
19	1	3	73	4	9	127	7	F	181	B	5	235	E	B		
20	1	4	74	4	A	128	8	0	182	B	6	236	E	C		
21	1	5	75	4	B	129	8	1	183	B	7	237	E	D		
22	1	6	76	4	C	130	8	2	184	B	8	238	E	E		
23	1	7	77	4	D	131	8	3	185	B	9	239	E	F		
24	1	8	78	4	E	132	8	4	186	B	A	240	F	0		
25	1	9	79	4	F	133	8	5	187	B	B	241	F	1		
26	1	A	80	5	0	134	8	6	188	B	C	242	F	2		
27	1	B	81	5	1	135	8	7	189	B	D	243	F	3		
28	1	C	82	5	2	136	8	8	190	B	E	244	F	4		
29	1	D	83	5	3	137	8	9	191	B	F	245	F	5		
30	1	E	84	5	4	138	8	A	192	C	0	246	F	6		
31	1	F	85	5	5	139	8	B	193	C	1	247	F	7		
32	2	0	86	5	6	140	8	C	194	C	2					
33	2	1	87	5	7	141	8	D	195	C	3					
34	2	2	88	5	8	142	8	E	196	C	4					
35	2	3	89	5	9	143	8	F	197	C	5					
36	2	4	90	5	A	144	9	0	198	C	6					
37	2	5	91	5	B	145	9	1	199	C	7					
38	2	6	92	5	C	146	9	2	200	C	8					
39	2	7	93	5	D	147	9	3	201	C	9					
40	2	8	94	5	E	148	9	4	202	C	A					
41	2	9	95	5	F	149	9	5	203	C	B					
42	2	A	96	6	0	150	9	6	204	C	C					
43	2	B	97	6	1	151	9	7	205	C	D					
44	2	C	98	6	2	152	9	8	206	C	E					
45	2	D	99	6	3	153	9	9	207	C	F					
46	2	E	100	6	4	154	9	A	208	D	0					
47	2	F	101	6	5	155	9	B	209	D	1					
48	3	0	102	6	6	156	9	C	210	D	2					
49	3	1	103	6	7	157	9	D	211	D	3					
50	3	2	104	6	8	158	9	E	212	D	4					
51	3	3	105	6	9	159	9	F	213	D	5					
52	3	4	106	6	A	160	A	0	214	D	6					
53	3	5	107	6	B	161	A	1	215	D	7					

6 LEDS

Communication LED	Status
PWR	Displays the status of power
TX	Displays the status of sending of Comm. module
RX	Displays the status of receiving of Comm. module

7 NETWORK CABLE

a. Network Cable (RS-485)

MASTER Unit	Connection	SMART I/O Snet	
TX+	↔	3	RX-
TX-	↔	4	RX+
GND	↔	5	GND
RX+	↔	8	TX-
RX-	↔	9	TX+

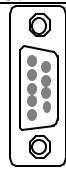

b. Modbus Support

Modbus ASCII Support	No
RTU Binary Support	Yes
Baud Rates	2400, 4800, 9600, 19.2K, 38.4K
Parity, Data Bits, Stop Bits	N, 8, 1
Handshaking	None
Modbus Commands Supported	3,4, 6,16
Modbus Offset	0

8 INSTALLATION / SAFETY

- All applicable codes and standards need to be followed in the installation of this product.
- For I/O wiring (discrete), use the following wire type or equivalent: Belden 9918, 18 AWG or larger.



Warning: Consult user documentation.



Warning: Electrical Shock Hazard.

9 TECHNICAL ASSISTANCE

For assistance, contact Technical Support at the following locations:

North America:
 (317) 916-4274
www.heapg.com.

Europe:
 (+) 353-21-4321-266
www.horner-apg.com.