



# AC Input /AC Output Module

*Mini OCS/RCS*

**HE500OCS036 / HE500OCS066  
HE500RCS066**

**120 VAC In, Positive Logic  
80-260 VAC Out, Positive Logic**

## 1 SPECIFICATIONS

INPUT			
Inputs per Module	8	Input Impedance	0.01 $\mu$ F +10K
Commons per Module	1	Isolation (Channel to Common)	500VDC
Input Voltage Range	120 – 160 VAC	Minimum ON Current	1mA.
Peak Voltage	160VAC	Maximum OFF Current	200 $\mu$ A.
AC Frequency	60Hz	OFF to ON Response	50ms.
ON Voltage Level	70VAC Min.	ON to OFF Response	50ms.
OFF Voltage level	30VAC Max.	Status Indicator	8

OUTPUT			
Outputs per Module	8	Maximum Load Current per output	.3A Max.
Commons per Module	1	Maximum Leakage Current	15 $\mu$ A Max.
Operating voltage	260VAC Max.	Maximum Inrush Current	500mA
Output Type	MOSFET	OFF to ON Response	10ms. Max.
Contact Voltage	260VAC Max.	ON to OFF Response	3ms. Max.
ON Voltage level	1V Max.		
Isolation (Channel to Channel and Channel to Common)	500VDC	Status Indicator	8

General Specifications			
Required Power (Steady State)	4.8W (200mA @ 24VDC)	Operating Temperature	0° to 50° Celsius
Required Power (Inrush)	900mA max. @ 24VDC for 1ms.	Terminal Type	Spring Clamp, Removable
Relative Humidity	5 to 95% Non-condensing	Weight	9.5 oz. (256 g)
CE	See Compliance Table at <a href="http://www.heapg.com/Support/compliance.htm">http://www.heapg.com/Support/compliance.htm</a>		
UL			

**MAN0300-03**

## 2 WIRING

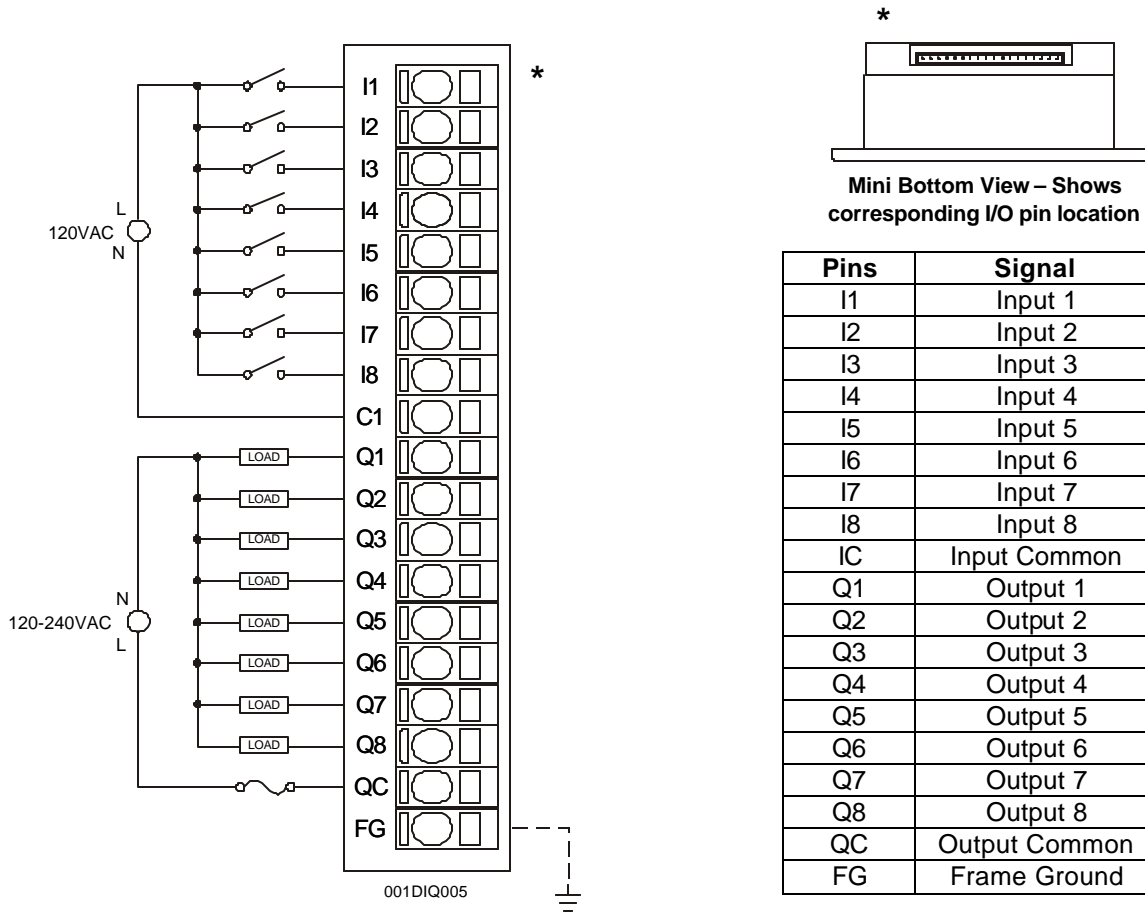

**Warning:** To protect the module and associated wiring from load faults, use external fuse (2.5A) as shown. This warning affects OCS036 / 066, Revisions E or higher and all versions of the Mini RCS066.

**Warning:** Connecting high voltage to any I/O pin may cause high voltage to appear at other I/O pins.

**Warning:** Wiring the line side of the AC source to loads connected to outputs 1 through 8 and the neutral side of the AC source to the output common(s) would create a Negative Logic condition, which may be considered an unsafe practice.

### 3 INTERNAL CIRCUIT SCHEMATICS

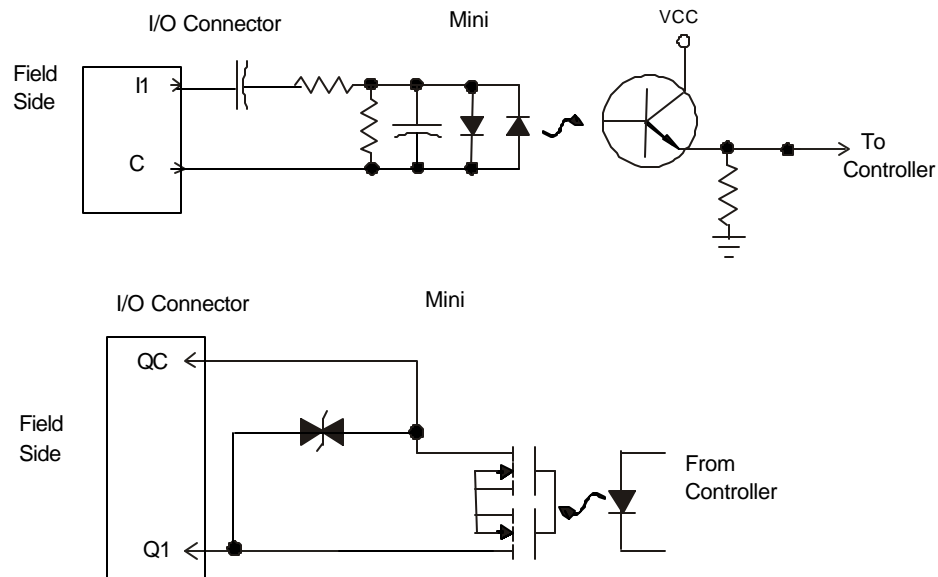

Specification for transient voltage suppressors (transorbs) used on output circuitry is 400VDC, bi-directional 400 watts.

### 4 CONFIGURATION

**Note:** The status of the I/O can be monitored in Cscape Software.

Selecting the **I/O Map** tab provides information about the I/O registers. The I/O Map is not edited by the user.

The **Module Setup** is used in applications where it is necessary to change the default states of the outputs when the controller (e.g., OCS100) enters idle/stop mode. The default turns the outputs OFF when the controller enters idle/stop mode. By selecting the Module Setup tab, each output can be set to either turn ON, turn OFF or to hold the last state. Generally, most applications use the default settings.

**Warning:** The default turns the outputs OFF when the controller enters idle/stop mode. To avoid injury of personnel or damages to equipment, exercise extreme caution when changing the default setting using the **Module Setup** tab.

## 5 INSTALLATION / SAFETY

**Warning:** Previous versions of this product provided internal fuses on the output circuits (relay contacts). Due to CE Low Voltage Directive (LVD) marking requirements, these fuses have been removed and replaced with solid wire. Therefore, it is now the responsibility of the user of this equipment to ensure that adequate fusing is installed *externally* on each relay output circuit.

- a. All applicable codes and standards are to be followed in the installation of this product.
- b. Use the following wire type or equivalent: Belden 8917, 16 AWG or larger.

For detailed installation information, refer to Mini Hardware Manual. A handy checklist is provided that covers panel box layout requirements and minimum clearances.

When found on the product, the following symbols specify:



**Warning:** Consult user documentation.



**Warning:** Electrical Shock Hazard.

## 6 INPUT / OUTPUT CHARACTERISTICS

Digital Input Chart

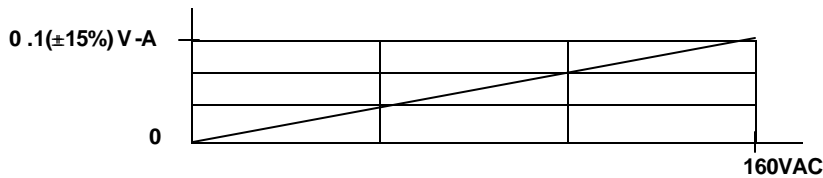

Derating Output Chart

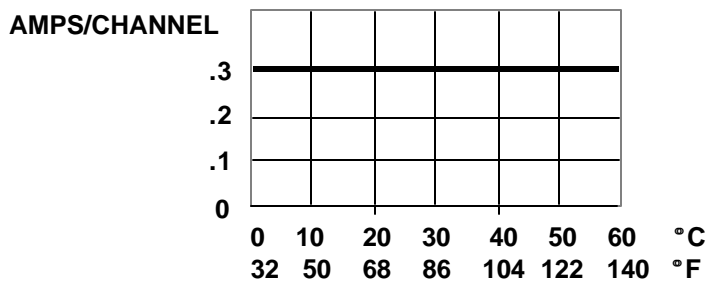

The following applies to applications in which two-wire proximity switches are used as sensors for discreet AC inputs. For these applications, an external resistor *or* resistor/capacitor combination must be added to each input as shown below. The resistor provides a small current to power the proximity switch. The resistor is not required for other types of proximity switches.

120VAC: 15K ohm, 2W resistor *or* 0.22 $\mu$ F metallized film capacitor rated for 120VAC service in series with 470 ohm, 0.5W resistor

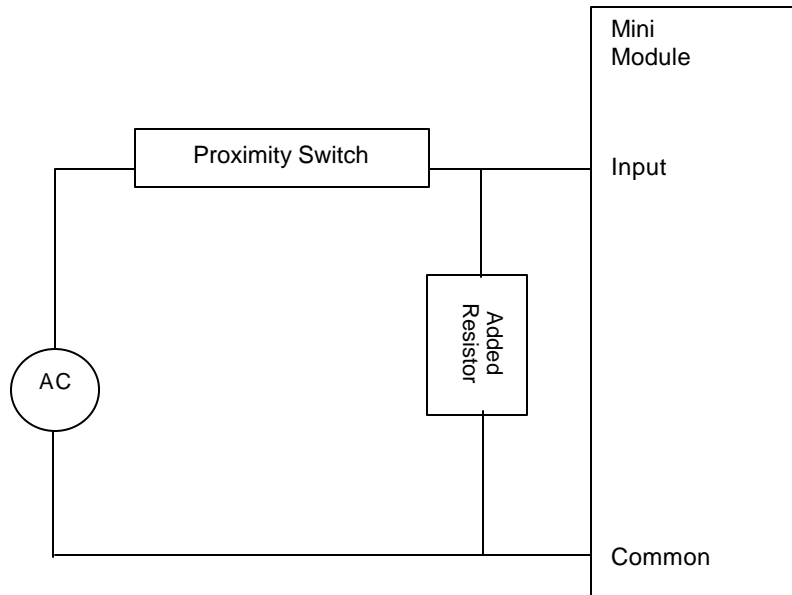

## 7 TECHNICAL ASSISTANCE

For assistance, contact Technical Support at the following locations.  
Please visit our website for manual updates.

**North America:**  
(317) 916-4274  
[www.heapg.com](http://www.heapg.com)

**Europe:**  
(+) 353-21-4321-266  
[www.horner-apg.com](http://www.horner-apg.com)

NOTES