



User Manual for the
HE693SER300

Sequence of Events Recorder Module

Second Edition
November 25, 2003

MAN0078-02

PREFACE

This manual explains how to use the Sequence of Events Recorder Module.

Copyright (C) 2003, Horner APG, LLC, 640 North Sherman Drive, Indianapolis, Indiana 46201. All rights reserved. No part of this publication may be reproduced, transmitted, transcribed, stored in a retrieval system, or translated into any language or computer language, in any form by any means, electronic, mechanical, magnetic, optical, chemical, manual or otherwise, without the prior agreement and written permission of Horner APG, LLC.

All software described in this document or media is also copyrighted material subject to the terms and conditions of the Horner Software License Agreement.

Information in this document is subject to change without notice and does not represent a commitment on the part of Horner APG, LLC.

Series 90-30 and Logicmaster are trademarks of GE Fanuc Automation North America, Inc.

DOS and MS-DOS are trademarks of Microsoft Corporation.

LIMITED WARRANTY AND LIMITATION OF LIABILITY

Horner APG, LLC ("HE") warrants to the original purchaser that the Sequence of Events Recorder Module manufactured by HE is free from defects in material and workmanship under normal use and service. The obligation of HE under this warranty shall be limited to the repair or exchange of any part or parts which may prove defective under normal use and service within two (2) years from the date of manufacture or eighteen (18) months from the date of installation by the original purchaser whichever occurs first, such defect to be disclosed to the satisfaction of HE after examination by HE of the allegedly defective part or parts. THIS WARRANTY IS EXPRESSLY IN LIEU OF ALL OTHER WARRANTIES EXPRESSED OR IMPLIED INCLUDING THE WARRANTIES OF MERCHANTABILITY AND FITNESS FOR USE AND OF ALL OTHER OBLIGATIONS OR LIABILITIES AND HE NEITHER ASSUMES, NOR AUTHORIZES ANY OTHER PERSON TO ASSUME FOR HE, ANY OTHER LIABILITY IN CONNECTION WITH THE SALE OF THIS SEQUENCE OF EVENTS RECORDER MODULE. THIS WARRANTY SHALL NOT APPLY TO THIS SEQUENCE OF EVENTS RECORDER MODULE OR ANY PART THEREOF WHICH HAS BEEN SUBJECT TO ACCIDENT, NEGLIGENCE, ALTERATION, ABUSE, OR MISUSE. HE MAKES NO WARRANTY WHATSOEVER IN RESPECT TO ACCESSORIES OR PARTS NOT SUPPLIED BY HE. THE TERM "ORIGINAL PURCHASER", AS USED IN THIS WARRANTY, SHALL BE DEEMED TO MEAN THAT PERSON FOR WHOM THE SEQUENCE OF EVENTS RECORDER MODULE IS ORIGINALLY INSTALLED. THIS WARRANTY SHALL APPLY ONLY WITHIN THE BOUNDARIES OF THE CONTINENTAL UNITED STATES.

In no event, whether as a result of breach of contract, warranty, tort (including negligence) or otherwise, shall HE or its suppliers be liable of any special, consequential, incidental or penal damages including, but not limited to, loss of profit or revenues, loss of use of the products or any associated equipment, damage to associated equipment, cost of capital, cost of substitute products, facilities, services or replacement power, down time costs, or claims of original purchaser's customers for such damages.

To obtain warranty service, return the product to your distributor with a description of the problem, proof of purchase, post paid, insured and in a suitable package.

ABOUT PROGRAMMING EXAMPLES

Any example programs and program segments in this manual or provided on accompanying diskettes are included solely for illustrative purposes. Due to the many variables and requirements associated with any particular installation, Horner APG cannot assume responsibility or liability for actual use based on the examples and diagrams. It is the sole responsibility of the system designer utilizing the Sequence of Events Recorder Module to appropriately design the end system, to appropriately integrate the Sequence of Events Recorder Module and to make safety provisions for the end equipment as is usual and customary in industrial applications as defined in any codes or standards which apply.

Note: The programming examples shown in this manual are for illustrative purposes only. Proper machine operation is the sole responsibility of the system integrator.

Revisions to this Manual.

1. Revised Table 4.1.
2. Revised Section 4.7: LEDs.

TABLE OF CONTENTS

PREFACE 3

LIMITED WARRANTY AND LIMITATION OF LIABILITY 4

ABOUT PROGRAMMING EXAMPLES 4

TABLE OF CONTENTS 7

CHAPTER 1: INTRODUCTION 9

 1.1 HE693SER300 Product Description 9

 1.2 Overview of the Sequence of Events (See Figure 1.1) 9

CHAPTER 2: INSTALLATION 11

 2.1 General 11

 2.2 CAN Interface 11

 2.2 HE693SER300 Grounding Information 12

CHAPTER 3: CONFIGURATION SOFTWARE FOR THE HE693SER300 13

 3.1 General 13

 3.2 Configuration Procedures 13

CHAPTER 4: OPERATION 17

 4.1 Functions 17

 4.2 Recording Events and Updating Digital Output Modules (See Figure 1.1 for Overview) 17

 4.3 HE693SER300 Module CAN Messaging 17

 4.4 GPS Time Server (TIM100) 18

 4.5 Input Signal Specification (Received from GE Fanuc Digital Input Modules) 18

 4.6 Guidelines for Proper Input Signal Generation for Digital I/O Modules Used with the SER300 18

 4.7 LED Indicators 19

APPENDIX A: GE FANUC SERIES 90-30 DISCRETE I/O MODULE SPECIFICATIONS 21

APPENDIX B: INPUT SIGNAL SPECIFICATIONS (CASE EXAMPLE) 23

 1 General 23

 2 Proper Input Signal Generation 23

 3 Parameters for IC693MDL655 Digital Input Module (Case Example) 24

THIS PAGE INTENTIONALLY LEFT BLANK

CHAPTER 1: INTRODUCTION

1.1 HE693SER300 Product Description

The HE693SER300 Sequence of Events Recorder Module (SER300) time stamps and records events with a time resolution of one millisecond and resides in the CPU slot of a GE Fanuc 90-30 rack (IC693CHS397 or IC693CHS391). The SER300 uses 200mA of current steady state, and draws 210 mA of in-rush current. Each SER300 is able to scan up to 256 digital input points of GE Fanuc Digital I/O Modules. Up to eight SER300 modules may be connected together on a Controller Area Network (CAN) bus by using a corresponding number of GE Fanuc 90-30 racks. Each SER300 is capable of storing 1,000 time stamped events.

1.2 Overview of the Sequence of Events (See Figure 1.1)

The SER300 allows users to track and create a history log of events over a CAN bus. An event is defined as any transition from ON to OFF (or OFF to ON) for one or more digital inputs. A CAN network consists of up to eight SER300s along with one time server (e.g.; HE200TIM100) and one CAN data concentrator (e.g.; HE693CDC300). A GE Fanuc CPU and Digital I/O Modules are also used in the applications. The following explanation describes how the above equipment functions together to record events and allow communication between remote I/O racks over a CAN bus:

a. The CDC300 is responsible for retrieving data from the SER300 and providing the data to the GE Fanuc CPU. The CDC300 also sends commands from the GE Fanuc CPU to the SER300. Upon receiving a CAN message from the SER300 that an event has occurred, the CDC300 notifies the GE Fanuc CPU and awaits instructions. The CPU, then, sends instructions to the CDC300. The CDC300 passes the instructions to the SER300 via the CAN network.

Examples of CAN message commands to the SER300 include the retrieval of event data and to enable/disable event recording or to provide update information to the GE Fanuc Digital Output Modules.

b. The CDC300 sends CAN message commands to the SER300 via the CAN network. The SER300 executes the commands and then provides acknowledgements to the CDC300.

c. The TIM100 Time Server provides a stable 100 microsecond time reference to the CAN bus and is used to keep the network's SER300s in synchronization with each other. It also provides synchronization with SER300s in other networks.

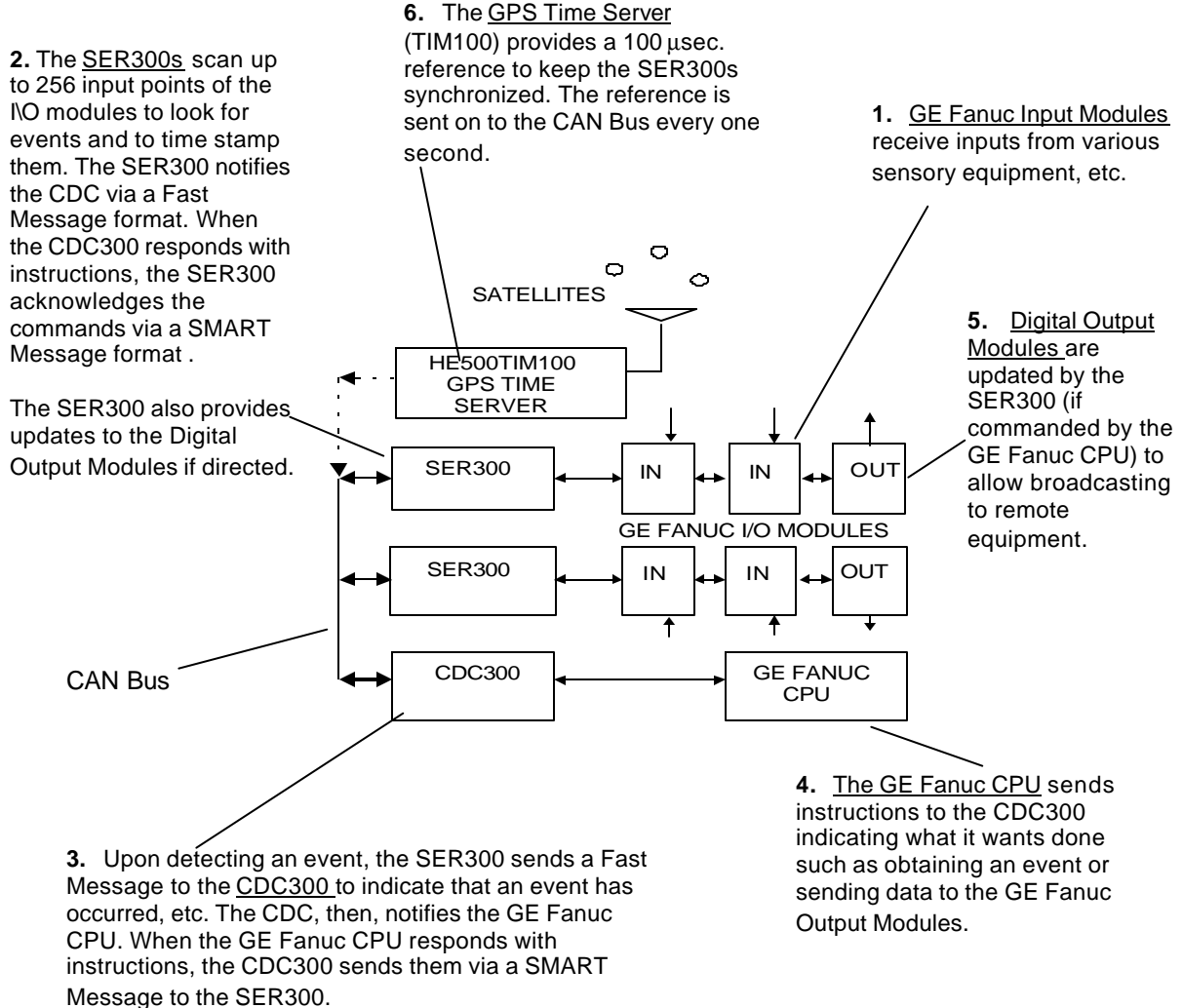

Figure 1.1 – Sequence of Events Recorder

1.3 Technical Assistance

For assistance or to check for periodic manual updates, contact the following resources.

North America:

(317) 916-4274
www.heapg.com

Europe:

(+) 353-21-4321-266
www.horner-apg.com

CHAPTER 2: INSTALLATION

2.1 General

The SER300 Module plugs into the CPU slot of a GE Fanuc Series 90-30 rack. Consult the following for wiring information. The information below contains wiring details for the SER300:

2.2 CAN Interface

The CAN Interface utilizes a 5-pin Phoenix-type connector (figure 2-1). When wiring modules together in a CAN system, certain wiring rules must be followed in order for the system to work properly. The rules below should be applied.

1. A CAN network should be wired in a daisy-chained fashion, such that there are exactly two physical endpoints on the network.
2. The two nodes at the physical endpoints should have 120ohm terminating resistors connected across "CAN-H" and "CAN-L."
3. The data conductors (CAN-H and CAN-L) should be a high quality shielded twisted pair.
4. Only one end of the shield should be connected. Grounding both ends of the shield can cause ground loops and induce noise.

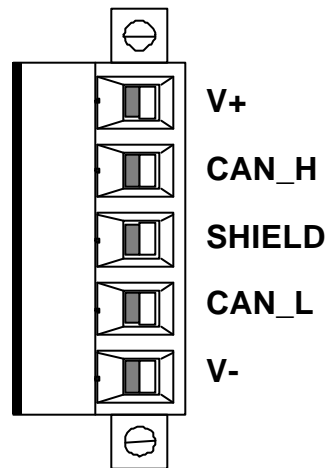

Figure 2.1 - 5-Pin Phoenix Connector

2.2 HE693SER300 Grounding Information

The SER300 must be connected to frame ground at the slot where it is installed. The following text and figure represent the proper grounding technique for the SER300. Grounding this device is similar to grounding a GE Fanuc CPU 351 and 352.

The connection from the SER300 to frame ground can be made using a green ground wire included with the SER300.

The wire has a quick-slide connector on one end for connection to a mating terminal on the bottom of the CPU, and a ring terminal on the other end for connection to a grounded enclosure.

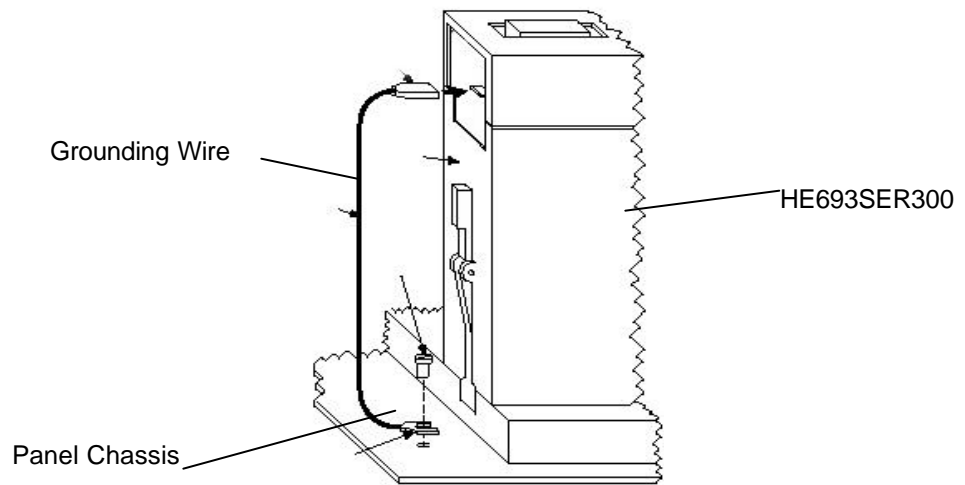

Figure 2.2 – Grounding SER300 to Panel Chassis

CHAPTER 3: CONFIGURATION SOFTWARE FOR THE HE693SER300

3.1 General

Prior to use, the HE693SER300 Sequence of Events Recorder Module needs to be configured with the HECFG.EXE PC DOS tool. The software tool is shipped on diskette with the SER300. An IBM-compatible computer using DOS version 3.3 or higher is required to configure the SER300.

The purpose of the software tool (HECFG.exe) is to configure the HE693SER300 for use with the HE693CDC300. This allows the devices to communicate via the CAN bus. The HE693CDC300 is configured using Logicmaster 90 (LM90). (See the *HE693CDC300 users manual for complete configuration instructions*).

3.2 Configuration Procedures

In order for the SER and the CDC (or other CAN devices) to communicate successfully on the CAN bus, the baud rate and address must be configured properly. The CAN Node number (also known as the address) can be set from 1 to 30. The CDC300 on the network must be configured with a different node number (usually 30).

Baud Rate / Maximum Cable (in meters)				
Baud Rate	125K	250K	500K	1Meg
Maximum Cable (m)	500	250	100	25

a. Configuration of Node Number (Address)

In order to configure a node number for the SER300, the HECFG.exe configuration software must be used. To use the software, simply go to the path in DOS where the program is located and type in HECFG. If Communication Port 2 is to be used, type in HECFG 2. The screen below should appear.

```

Horner Electric Smart Configurator
Version 0.20 - Ken Jannotta Jr.

1) Load new firmware
2) Configure the module
3) Force Configure Mode <Loop Back>
4) Exit

```

Figure 3.1

1. After the screen in Figure 3.1 appears, connect a cable from Communications Port 1 of the PC to the RS-485 port on the power supply of the Series 90-30 rack that contains the SER300. An HE693SNP232 (RS-485 to RS232 adapter) is needed for this connection. With the cable connected and the SER300 powered up, press 2 to select "Configure the module". The following screen will appear:

```

Horner Electric Smart Configurator
Version 0.20 - Ken Jannotta Jr.

HE693SER300B Sequential Event Recorder
Firmware Version: x.xx August 14, 1997

CAN Node Number: 030
CAN Baud Rate: 125K
Number of Input Bytes: 032
Number of Output Bytes: 008
Send Current Time Once per Second: OFF
Send Inputs on Change of State: OFF
Number of Events Stored: 00000

ESC = Back  F2 = Stop Target  F3 = Start Target  F4 = Reset Target  F9 = Load

```

Figure 3.2

NOTE: For greater accuracy (if the following features are *not* required): Configure the "Send Current Time Once per Second" to OFF and also configure the "Send Inputs on Change of State" to OFF. See above screen.

2. To configure the CAN Node Number, move the highlight over the "CAN Node Number" parameter and press Enter. The following screen will appear:

```

Horner Electric Smart Configurator
Version 0.20 - Ken Jannotta Jr.

Parameter: CAN Node Number
Value: 30
Enter a value from 1 to 30

<ENTER> = Save      <ESC> = Cancel
<PGUP> = Previous  <PGDN> = Next

ESC = Back  F2 = Stop Target  F3 = Start Target  F4 = Reset Target  F9 = Load

```

Figure 3.3

3. Enter the address number for the connected HE693SER300 and press `Enter`. The CAN Node address number is now configured.

To configure the baud rate, escape from the previous page to the configuration screen (Figure 3-2). Highlight the CAN baud rate parameter and press `Enter`. The following screen will appear (Figure 3-4):

```
Horner Electric Smart Configurator
Version 0.20 - Ken Jannotta Jr.

Parameter: CAN Baud Rate
Value: 125K

Select from: 125K 250K 500K 1M
              Press <SPACE> to toggle options.

ESC = Back  F2 = Stop Target  F3 = Start Target  F4 = Reset Target  F9 = Load
```

Figure 3.4

4. Press the Space bar to toggle through the different baud rates. Press the `Enter` key when the desired baud rate is highlighted.

Note: The baud rates must be the same for all the modules on the CAN network.

To configure the number of Digital Inputs, go to the configuration screen (Figure 3-2). Position the highlight over the "Number of Input Bytes" parameter and press the `Enter` key. The following screen will appear:

```
Horner Electric Smart Configurator
Version 0.20 - Ken Jannotta Jr.

Parameter: Number of Input Bytes
Value: 32
Enter a value from 1 to 32
              <ENTER> = Save      <ESC> = Cancel
              <PGUP> = Previous  <PGDN> = Next

ESC = Back  F2 = Stop Target  F3 = Start Target  F4 = Reset Target  F9 = Load
```

Figure 3.5

Enter in the maximum number of input bytes to be scanned and press the `Enter` key.

To configure the maximum number of Digital Outputs, go to the Configuration Screen (Figure 3-2).

NOTE: Each byte enables 8 input channels to be scanned. If fewer channels are found in the rack than are configured, only the channels in the modules that are physically present in the rack are scanned.

Place the highlight over the Number of Output Bytes Parameter. Press the `Enter` key. The following screen will appear (Figure 3-6):

```
Horner Electric Smart Configurator
Version 0.20 - Ken Jannotta Jr.

Parameter: Number of Output Bytes
Value: 8
Enter a value from 0 to 8

      <ENTER> = Save      <ESC> = Cancel
      <PGUP>  = Previous  <PGDN> = Next

ESC = Back  F2 = Stop Target  F3 = Start Target  F4 = Reset Target  F9 = Load
```

Figure 3.6

Enter in the maximum number of output bytes and press the `Enter` key.

The SER300 Module is now configured.

CHAPTER 4: OPERATION

4.1 Functions

The SER300 has three main functions:

- a. Digital Input event recording;
- b. Digital Output updating;
- c. CAN network communication.

A CAN network consists of up to eight SER300s along with one Time Server (HE200TIM100) and one CAN Data Concentrator (such as the HE693CDC300). A GE Fanuc CPU and Digital I/O Modules are also used in the applications.

4.2 Recording Events and Updating Digital Output Modules (See Figure 1.1 for Overview)

The sequence of events starts with the GE Fanuc Digital Input Module(s) receiving inputs from various sensory equipment. The SER300 scans the Digital Input Module(s) to determine if an event has occurred. (An event is defined as any transition from ON to OFF [or from OFF to ON] on one or more digital inputs.)

Upon detection of an event, the data is time stamped and recorded in the SER300's Event Table. The SER300 notifies the CDC300 of the event using a Fast Message format. The CDC300, then, notifies the GE Fanuc CPU. The GE Fanuc CPU sends instructions such as having the CDC300 obtain an event from the SER300 and for the SER300 to clear its Event Table.

If desired, the GE Fanuc CPU also sends update information to the Digital Output Modules via the CDC300 and the SER300. This allows the Digital Output Modules to control to remote equipment.

Internal timing of the SER300s is maintained at a resolution of 100 microseconds by using the Horner Electric TIM100. The TIM100 is a satellite-based time source which provides a stable time reference to synchronize the SER300s in its network and to synchronize with SER300s that are in other networks.

4.3 HE693SER300 Module CAN Messaging

Two types of messages are used to exchange data between the SER300 and other equipment on the CAN bus:

Fast messages and Smart messages.

1. Fast messages allow the transfer of raw data between CAN nodes and provide information such as notifying the CDC300 of the time and current status of a digital input. They are sent in a single packet.
2. Smart messages establish a command/response protocol to allow the transfer of any type of data between CAN nodes. Examples of Smart messages include commands such as telling the SER300 to clear its event table or to enable the recording of events. Smart responses from the SER300 include acknowledging the clearing of its event table or enabling the recording of events. Smart messages often contain multiple packets of information.

The SER300 exchanges CAN messages with other CAN Nodes (such as the CDC300 Data Concentrator Module) by sending an 11-bit Identifier and up to eight data bytes. The 11-bit Identifier specifies Message Priority, Node ID, and Message Type. The data bytes depend on the Message Type.

Table 4.1 shows the bit-mapped Smart Message Function Codes supported by the SER300:

Table 4.1 - Smart Message Function Codes			
Function Code	Function	Data Count	Description
1	Get Event	9-40	Command sends 0 data bytes; Response returns Event Time Stamp in 8-byte packed BCD followed by 1 to 32 input data bytes.
2	Clear Event Table	0	Command tells the SER300 to clear its Event Table; Response acknowledges clearing of Event Table.
4	Enable Event Recording	0	Command is modal; if 4's bit is 1, tells the SER300 to Enable Event Recording; if 4's bit is 0, tells SER300 to Disable Event Recording; Response acknowledges the enable or disable.
8	Get Status	0	Command tells the SER300 to send Fast Message Data Set 5, (2-byte Status Register and 2-byte Firmware Version Number); May be used to verify SER300's presence.
16	Update Outputs	1 to 8	Command sends 1 to 8 data bytes containing Digital Output data; Response acknowledges updating of the Digital Outputs.
32	Send Mask	4	Sends an input mask from the CDC to the SER. The mask allows filtering certain channels of input so these inputs do not cause a change of state. When a channel is filtered it does not cause an event to be recorded and does not cause the input data to be sent.

4.4 GPS Time Server (TIM100)

The SER300 maintains an internal resolution of 100 microseconds via network messages from the HE200TIM100 GPS Time Server (TIM100). The TIM100 receives timing inputs from GPS satellites and provides a 100 microsecond reference for the proper synchronization of the SER300s. If there is a loss of satellite communications, the TIM100's back-up clock is able to maintain synchronization of the SER300s that are a part of its network. However, the TIM100 is unable to sync up with SERs that are not a part of its network until satellite communications are restored. **(See the HE200TIM100 GPS Time Server User Manual for more information.)**

4.5 Input Signal Specification (Received from GE Fanuc Digital Input Modules)

In order to maintain the timing specifications on the SER300, the input signals received from the GE Fanuc Digital Input Module(s) must meet specific waveform requirements. The waveform specifications vary depending upon the Digital I/O Modules that are used. It is important to follow the general guidelines listed below for proper signal generation for any Digital I/O Modules that are used:

4.6 Guidelines for Proper Input Signal Generation for Digital I/O Modules Used with the SER300

AC input modules add a large and varying delay to the input signal. If the error for input stamping must be below 10 milliseconds, do not use AC input modules.

The voltage of the input signal should be within the module's specifications and should be consistent for all of the signals applied to the module. When voltages go above or below the specified value, the input filtering and detection circuitry may alter the delay between the input and the SER300.

The rise and fall time of the input signals should be kept to a minimum value and should be consistent for all of the signals applied to the module. The noise on the input signals should be kept to a minimum value and should be consistent for all of the signals applied to the module.

For a list of Digital I/O Modules that can be used with the SER300, see **Appendix A**. For information on the input waveform requirements (using IC693MDL655 Digital Input Module as a case example), see **Appendix B**.

4.7 LED Indicators

a. SER300 LEDs

The HE693SER300 features two bi-color LED indicators which provide information for front panel diagnostics and indicate the current status of the unit. The two LED indicators are the **NS Lamp** (Network Status) and the **MS Lamp** (Module Status).

a. The **MS Lamp** shows the status of the module by indicating if the SER300s are being synchronized by the GPS Time Source. It depicts if events have been captured and stored in memory. The MS Lamp also indicates if the SER300's Event Buffer is full. (1,000 events may be stored in each SER300). It is important to note that if the Event Buffer is full, no new events are over written or stored in memory.

b. The **NS Lamp** indicates whether the network is operating normally or if the network is inoperative. It also shows the reliability of the network by indicating if excessive CAN network errors are recorded.

Tables 4.2 and 4.3 list the LED states for the **MS Lamp** and the **NS Lamp**:

Table 4.2 – SER300 MS LED Status	
MS LED INDICATOR (Module Status)	MS LED STATES
GREEN element ON:	Sync with GPS Time Source (Satellite)
GREEN element OFF:	No GPS Time Source sync.
RED element ON:	Events have been captured and are being stored in the Events Table.
RED element OFF:	No events are being stored in the Events Table.
RED element FLASHING:	The event buffer is full. (Note: When the event buffer is full, new events are ignored.)
ORANGE	Occurs when GREEN and RED elements are both ON at the same time.

Table 4.3 – SER300 NS LED Status	
NS LED INDICATOR (Network Status)	NS LED STATES
GREEN element ON:	Network operating normally
RED element ON:	CAN network power not available or network inoperative (Network communications not possible)
RED element BLINKING (1 Hz)	Excessive CAN network errors recorded. (Communications unreliable)

b. **Additional LEDs (CDC300 and TIM100)**

The SER300 is used with the TIM100 and CDC300. For your convenience, the LED indicator states for these units are provided.

Table 4.4 – TIM100 NS LED Status	
NS LED INDICATOR (Network Status)	NS LED STATES
RED element ON	Network fault
GREEN element ON:	Network OK

Table 4.5 – TIM100 MS LED Status	
MS LED INDICATOR (Module Status)	MS LED STATES
RED element ON:	During Initialization
GREEN element ON:	Tracking satellites
MS lamps OFF	Not tracking satellites

Table 4.6 – CDC300 NS LED Status	
NS LED INDICATOR (Network Status)	NS LED STATES (Bi-Color LEDS)
GREEN element Flashes Irregularly:	CDC300 transmits data to CAN Network
RED element Flashes Irregularly	CDC300 receives data from CAN Network
RED element Blinks @ 1Hz rate	CAN Network down
RED element Solid ON	CAN connector is not powered

Table 4.7 – CDC300 MS LED Status	
MS LED INDICATOR (Module Status)	MS LED STATES (Bi-Color LED)
RED element OFF:	MS LED not used – always OFF
GREEN element OFF:	MS LED not used – always OFF

APPENDIX A: GE FANUC SERIES 90-30 DISCRETE I/O MODULE SPECIFICATIONS

CATALOG NUMBER	DESCRIPTION	NUMBER OF I/O POINTS
IC693MDL230	Input – 120 VAC Isolated	8
IC693MDL231	Input – 240 VAC Isolated	8
IC693MDL240	Input – 120 VAC	16
IC693MDL241	Input - 24 VAC/DC Positive/Negative Logic	16
IC693MDL632	Input – 125 VDC Positive/Negative Logic	8
IC693MDL634	Input – 24 VDC Positive/Negative Logic	8
IC693MDL645	Input - 24 VDC Positive/Negative Logic	16
IC693MDL646	Input - 24 VDC Positive/Negative Logic, Fast	16
IC693ACC300	Input Simulator	8 or 16
IC693MDL310	Output – 120 VAC, 0.5A	12
IC693MDL330	Output – 120/240 VAC, 2 A	8
IC693MDL340	Output - 120 VAC, 0.5A	16
IC693MDL390	Output - 120/240 VAC Isolated, 2A	5
IC693MDL730	Output – 12/24 VDC Positive Logic, 2A	8
IC693MDL731	Output - 12/24 VDC Negative Logic, 2A	8
IC693MDL732	Output - 12/24 VDC Positive Logic, 0.5A	8
IC693MDL733	Output - 12/24 VDC Negative Logic, 0.5A	8
IC693MDL734	Output – 125 VDC Positive/Negative Logic, 1A	6
IC693MDL740	Output - 12/24 VDC Positive Logic, 0.5A	16
IC693MDL741	Output - 12/24 VDC Negative Logic, 0.5A	16
IC693MDL742	Output - 12/24 VDC Positive Logic, ESCP, 1A	16
IC693MDL930	Output – Relay, N.O., 4A Isolated	8
IC693MDL931	Output –Isolated Relay, N.C. and Form C, 8A	8
IC693MDL940	Output – Relay, N.O., 2A	16
IC693MAR590	Input/Output – 120 VAC Input, Relay Output	8/8
IC693MDR390	Input/Output – 24 VDC Input, Relay Output	8/8
IC693MDL653	Input – 24 VDC Positive/Negative Logic FAST	32
IC693MDL654	Input – 5/12 VDC (TTL)Positive/Negative Logic	32
IC693MDL655	Input – 24 VDC Positive/Negative Logic	32
IC693MDL750	Output – 12/24 VDC Negative Logic	32
IC693MDL751	Output – 12/24 VDC Positive Logic	32
IC693MDL752	Output – 5/24 VDC (TTL) Negative Logic, 0.5A	32
IC693MDL753	Output – 12/24 VDC Positive Logic, 0.5A	32

NOTES

APPENDIX B: INPUT SIGNAL SPECIFICATIONS (CASE EXAMPLE)

NOTE: *The following case example is for provided for reference purposes only.*

1 General

- a. The information contained in the case example is for the Digital Input Module IC693MDL655.
- b. Input signal specifications vary depending upon the Digital Input Module(s) selected.
- c. For any Digital Input Module that is used, be sure to observe the "Guidelines for Proper Input Signal Generation for Digital Input Modules Used with the SER300" in Chapter 4: Operation, Section 4.6.

Table B.1 - Input Signal Specification from the IC693mdl655	
Required Input Signal Voltage	11.5 VDC > 25 VDC (Represents ON state.)
Minimum Rise Time of Input Signal	Approximately 25 μSec. minimum

2 Proper Input Signal Generation

With an input that activates by rising from 0 to 24 volts in less than 25 microseconds, the input delay is 600 microseconds with a variation of approximately 30 microseconds (Assumes a constant temperature of 20°C.)

Sample Input Delay Waveform

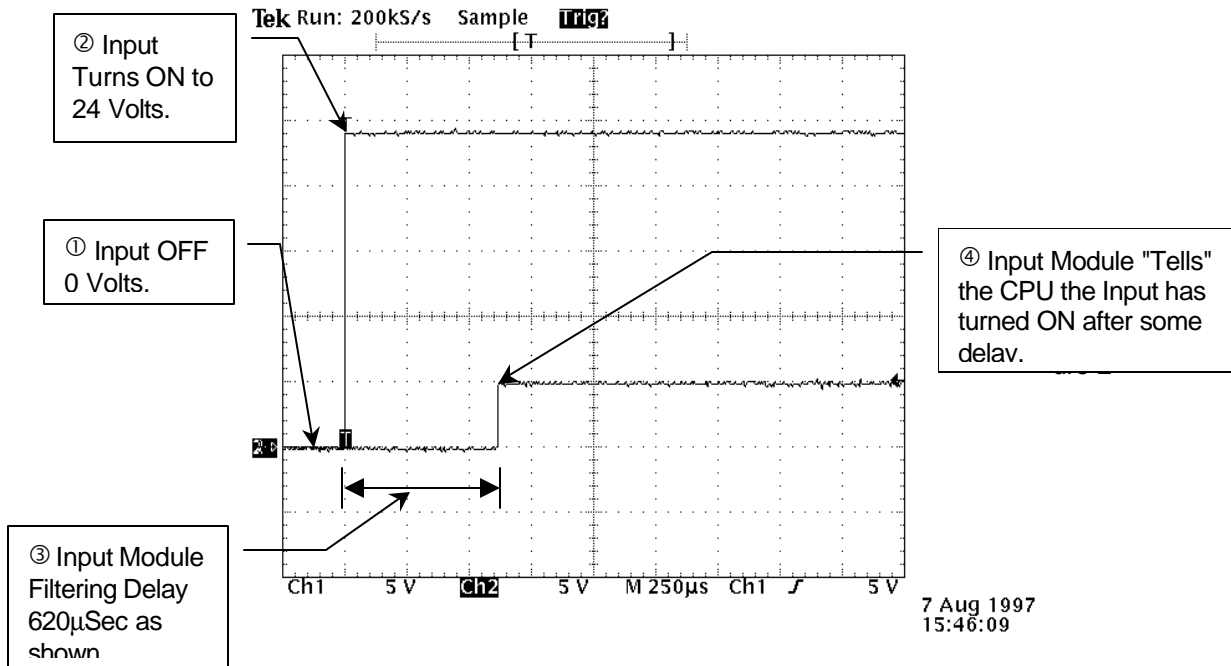

3 Parameters for IC693MDL655 Digital Input Module (Case Example)

a. Voltage for the IC693MDL655

The electrical specifications for the IC693MDL655 Module specify that required input voltage must be greater than 11.5 VDC and less than 25 VDC to represent an "ON" state. If the input signal follows these guidelines, the response time through the input module will be consistent enough to be recorded according to the HE693SER300 Module's specifications (approximately 0.6 to 0.7 milliseconds). **See Figures 2, 3, and 4.**

b. Rise-Time and Fall Time

The rise-time and the fall-time of the input signal should be a minimum value (approximately 25 microseconds). An excessive rise or fall time will cause the input to turn on at an inconsistent level (both time and voltage).

c. Noise

Noise should be kept to a minimum on the input signals. Noise can cause the filtering circuitry on the input modules to significantly increase or decrease the delay. When an input is OFF, the voltage (including additive noise) should be below 3 volts. When an input is ON, the voltage (including destructive noise) should be above 11.5 volts.

Figure 5 shows a simulation of noise from any AC power line (60Hz Sine wave) applied to the input of an IC693MDL655E module. In this case, the noise produces a peak positive offset of 3 volts. This causes little effect on the input delay.

Figure 6 is another simulation of power line noise. In this case, the noise has a peak positive offset of 7 volts. This causes the capacitors in the input filtering circuit to prematurely charge. When the input is activated, the input delay is now less than 100 microseconds.

The above noise is an example of additive noise. Destructive noise can reduce the voltage on an input. As seen in

Figure 1, reduced voltage can delay input activation by almost three milliseconds.

Note: Because noise can cause a relatively large variation in input delay, it is important to be properly grounded and shielded and to have proper supply filtering for accurate time stamping.

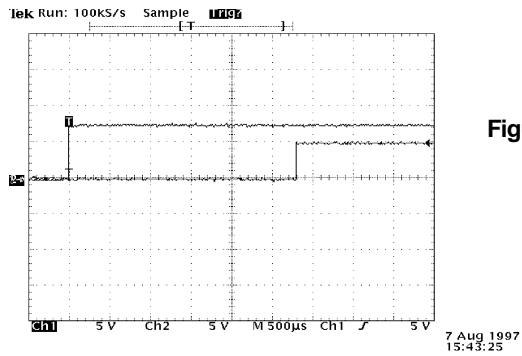

Figure 1

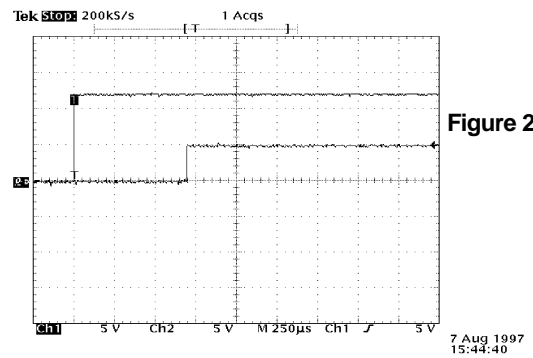

Figure 2

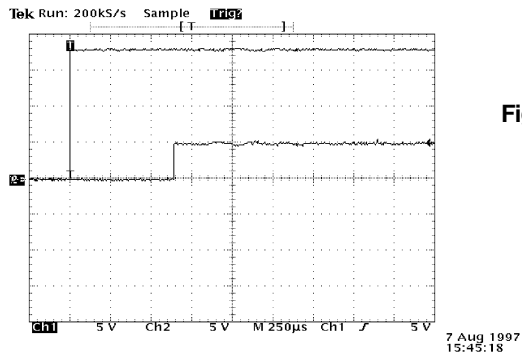

Figure 3

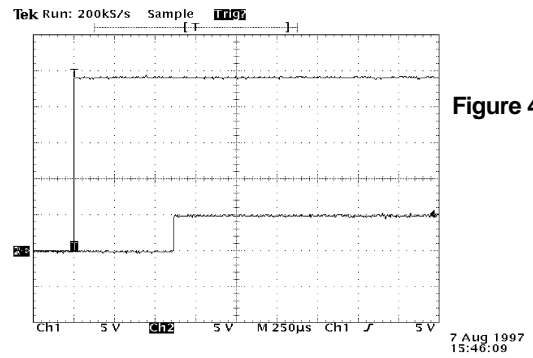

Figure 4

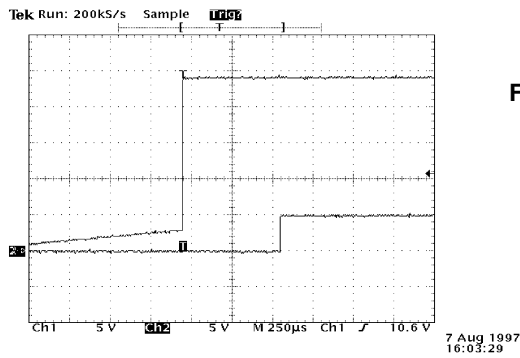

Figure 5

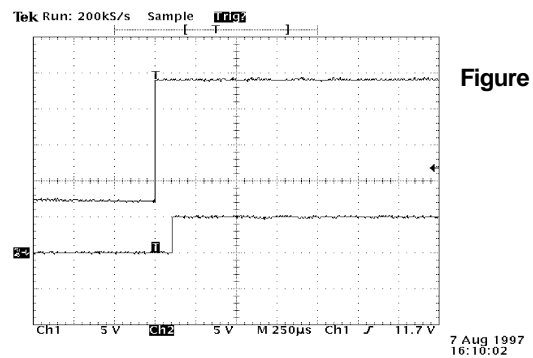

Figure 6

Figure B.2 - Case Example: IC693MDL655 Digital Input Module Wave Forms

NOTES