



Isolated Analog Current Input Module

Product Specifications and Installation Data

DESCRIPTION

Horner Electric Isolated Analog Current Input Modules provide four analog input channels, with 14-bits of resolution. Two models are available, the HE693ADC420 with 1500VAC (RMS) isolation, and the HE693ADC415 with 500VAC (RMS) isolation. These isolation levels are channel-to-channel and channel-to-ground. The modules convert the current input signals to digital values which are placed directly into the %AI table of the PLC CPU. Each channel may be configured for an input range of 4-20mA or +/-20mA. Each of the four channels has a programmable setpoint, the level of which is set in the PLC program via four %AQ output registers. If the analog input value reaches or exceeds the setpoint, a corresponding digital input %I is energized. The first four %Is represent the four input channel setpoint alarms, respectively.

ILLUSTRATION

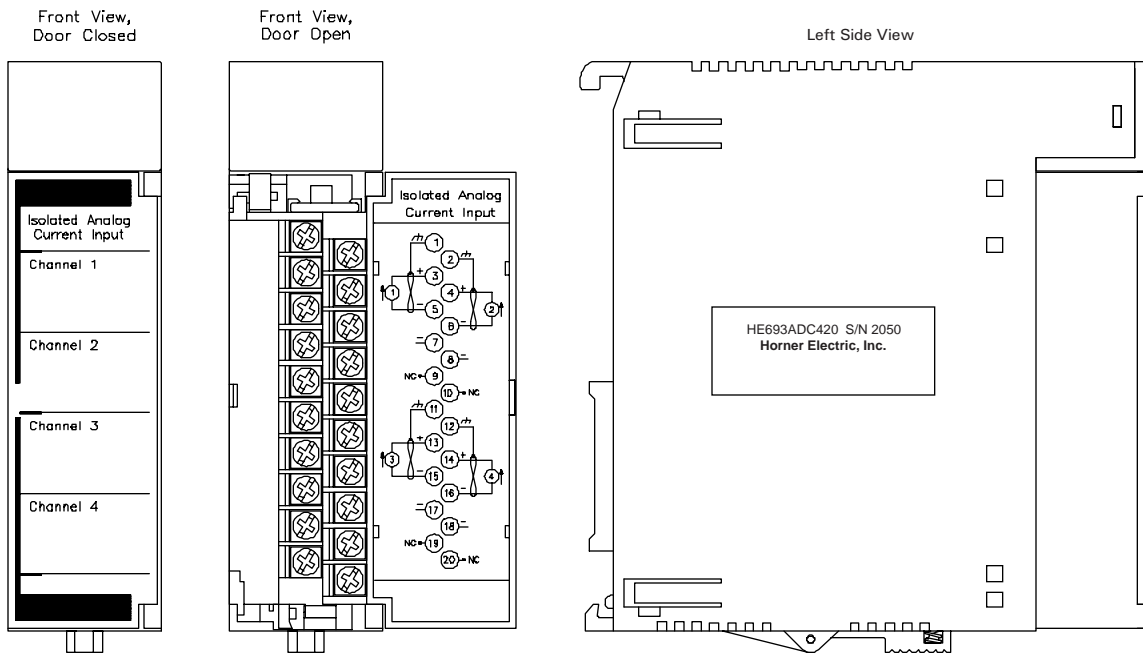

SPECIFICATIONS

Specification		Specification	
Power Consumption, Steady State	ADC415: .4W/80 mA @ 5V 2.16W/90 mA @ 24V ADC 420: .7W/140 mA at 5V 1.2W/50 mA @ 24V	Analog Filtering	1KHz, 3 pole Bessel
Surge Current at Power-Up	ADC415: 120mA @ 5V 150mA @ 24V ADC420: 200mA @ 5V 100mA @ 24V	Digital Filtering	1-128 samples/update
Number of Channels	4	Maximum Error	.05% full scale
I/O Required	4 %AI, 4 %AQ, 16%I	Channel to Channel (ADC420)	1500VAC (RMS), +/-2000VDC
Input Range	4-20mA, +/- 20mA	Common Mode Range (ADC420)	1500VAC (RMS), +/-2000VDC
A/D Type, Resolution	Integrating, 18 bits	Channel to Channel (ADC415)	500VAC (RMS), +/-700VDC
Useable Resolution	13 bits plus sign	Common Mode Range (ADC415)	500VAC (RMS), +/-700VDC
Module Update Rate	45 channels/S	Common Mode Rejection	>100dB
Input Impedance	100 ohms	Relative Humidity	5% to 95%, non-condensing
		Operating Temperature	0 to 60°C

SOFTWARE CONFIGURATION	
SLOT 2	Catalog #: FOREIGN FOREIGN MODULE
FRGN	<p>Module ID : 3</p> <p>%I Ref Adr : %I0001 Byte 1 : 00000001 Byte 9 : 00</p> <p>%I Size : 16 Byte 2 : 00000100 Byte 10 : 00</p> <p>%Q Ref Adr : %Q0001 Byte 3 : 00 Byte 11 : 00</p> <p>%Q Size : 0 Byte 4 : 00 Byte 12 : 00</p> <p>%AI Ref Adr : %AI001 Byte 5 : 00 Byte 13 : 00</p> <p>%AI Size : 4 Byte 6 : 00 Byte 14 : 00</p> <p>%AQ Ref Adr : %AQ001 Byte 7 : 00 Byte 15 : 00</p> <p>%AQ Size : 4 Byte 8 : 00 Byte 16 : 00</p>

LM90 Foreign Module Configuration. To reach this screen in the LM90 Configuration Package, select I/O Configuration (F1), cursor over to the slot containing the module and select Other (F8), and Foreign (F3).

%I Size	%AI Size	%AQ Size	Byte 1	Byte 2	Bytes 3-6
16	4	4	0001	0 thru 111(see chart)	00: 4-20mA 01: +/-20mA

Configuration Parameters. The necessary parameters are %I Size, %AI Size, %AQ Size, Byte 1, Byte 2, and Bytes 3-6.

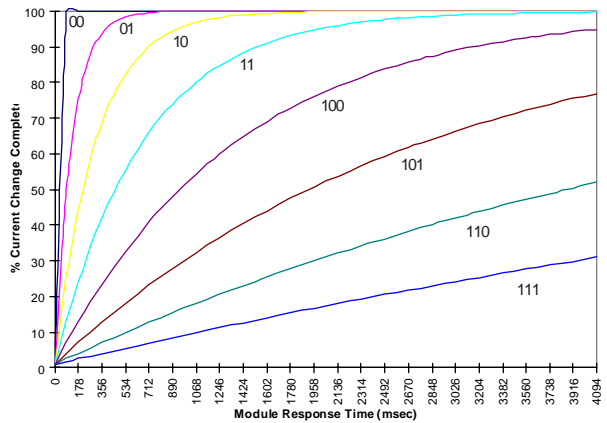

Mode	Scaling	Smallest Step Change
4-20mA	$mA = \%AI / 32,000 \times 16 + 4$	4 (dec) = 2uA
+/-20mA	$mA = \%AI / 32,000 \times 20$	4 (dec) = 2.5uA

Scaling. The modules convert each analog current into a decimal value between +/-32,000. The two least significant bits of each %AI are always 0, thus the smallest decimal step change is 4.

Digital Filtering. The effect of digital filtering (set with Byte 2) on module response to a change in current. (% current change completed vs. time).

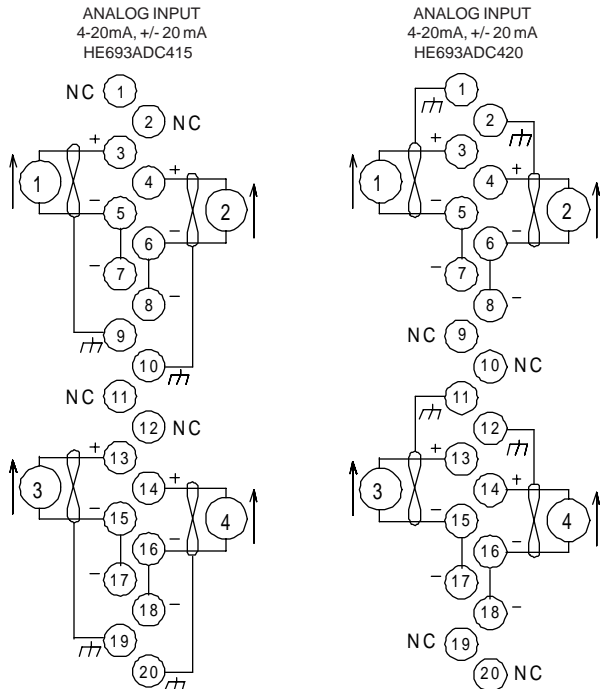

Installation Suggestions

- Wiring should be routed in its own conduit.
- Shielded, twisted pair extension wiring offers best noise immunity.
- If shielded wiring is used, a good earth ground connection, at one end only, is critical. If shields are grounded at the module end, terminals 9, 10, 19 and 20 on the ADC415, or terminals 1, 2, 11, and 12 on the ADC420 should be used as the shield connection.