



TxRail-USB

TEMPERATURE TRANSMITTER - OPERATING MANUAL – V2.0x B

INTRODUCTION

TxRail-USB is an USB configurable DIN rail mount temperature transmitter. It allows selection and configuration of input type, measurement range, output type and calibration. Its output can be set to either loop powered 4-20 mA or 0-10 Vdc. Highly accurate and user-friendly, the **TxRail-USB** performs well from simple to sophisticated measurement applications.

The output current or voltage is linearized according to the selected input sensor and adjusted to the configured range.

SPECIFICATIONS

Sensor input: User defined. The supported sensors are listed in **Table 1**, along with their maximum ranges.

Thermocouples: Types J, K, R, S, T, N, E and B, according to IEC 60584 (ITS-90). Impedance $\gg 1\text{ M}\Omega$

Pt100: Excitation 0.8 mA, $\alpha = 0.00385$, according IEC 60751 (ITS-90).

For 2-wire sensors, tie terminals 3 and 4 together.

Pt1000: Type 3-wire, Excitation 0.8 mA, $\alpha = 0.00385$, according IEC 60751 (ITS-90).

For 2-wire sensors, tie terminals 3 and 4 together.

NTC $R_{25^\circ\text{C}}$: 10 k Ω $\pm 1\%$, $B_{25/85} = 3435$

Voltage: 0 to 50 mVdc. Impedance $\gg 1\text{ M}\Omega$

0 to 100 mVdc. Impedance $\gg 1\text{ M}\Omega$ (*)

(*) Feature available for devices with firmware version starting at V2.0x.

Sensor Type	Maximum Measurement Range	Minimum Measurement Range
Voltage	0 to 50 mV	5 mV
Voltage	0 to 100 mV	10mV
Thermocouple K	-150 to 1370 °C	100 °C
Thermocouple J	-100 to 760 °C	100 °C
Thermocouple R	-50 to 1760 °C	400 °C
Thermocouple S	-50 to 1760 °C	400 °C
Thermocouple T	-160 to 400 °C	100 °C
Thermocouple N	-270 to 1300 °C	100 °C
Thermocouple E	-90 to 720 °C	100 °C
Thermocouple B	500 to 1820 °C	400 °C
Pt100	-200 to 650 °C	40 °C
Pt1000	-200 to 650 °C	40 °C
NTC	-30 to 120 °C	40 °C

Table 1 – Sensors accepted by the transmitter

Switch-on delay: < 2.5 s. The accuracy is only guaranteed after 15 minutes.

Terms of reference: ambient: 25 °C; voltage: 24 Vdc, load: 250 Ω ; settling time: 10 minutes

Temperature Effect: < $\pm 0.16\%$ / 25 °C

Response time: typical 1.6 s.

Maximum voltage allowed at input terminals no sensor: 3 V.

RTD current: 800 μA .

RTD cable resistance effect: 0.005 °C / Ω

Maximum allowable cable resistance for RTD: 25 Ω .

Sensor Type	Typical Accuracy	Maximum Accuracy
Pt100 / Pt1000 (-150 to 400 °C)	0.10 %	0.12 %
Pt100 / Pt1000 (-200 to 650 °C)	0.13 %	0.19 %
K, J, T, E, N, R, S, B	0.1 % (*)	0.15 % (*)
mV	0.1 %	0.15 %
NTC	0.3 °C	0.7 °C

Table 2 – Calibration error, percentage of the full measurement range.

(*) **Add cold junction compensation:** < ± 1 °C.

Power supply influence: 0.006 % / V typical (percentage of the full measure range).

Output (4-20 mA): 4-20 mA or 20-4 mA current, 2-wired; and proportional to the configured range.

Output Resolution (4-20 mA): 2 μA .

Output (0-10 Vdc): 0-10 Vdc or 10-0 Vdc voltage, and proportional to the configured range.

Output Resolution (0-10 Vdc): 0.0025 V (12 bits)

Power supply: 10 to 35 Vdc (output 4-20 mA) and 12 to 35 Vdc (output 0-10 Vdc).

Maximum load (RL): $RL(\text{m}\acute{\text{a}}\text{x}.) = (Vdc - 10) / 0.02 [\Omega]$

Where: Vdc= Power supply voltage (10-35 Vdc)

Operating Temperature: -40 to 85 °C

Humidity: 0 to 90 % RH

Electromagnetic Compatibility: EN 61326-1:2006

No electrical isolation between input and output.

Internal protection against polarity inversion.

Cold junction compensation for thermocouples.

Connection Wire Cross Section: 0.14 a 1.5 mm²

Screw Tightening: 0.8 Nm.

Housing: ABS UL94-HB.

Certification: CE, UKCA

CONFIGURATION

Changes to the configuration are possible through the **TxConfig II** software, provided free of charge.

The transmitter configuration interface (USB cable) can be purchased from the manufacturer or its authorized sales representatives.

The **TxConfig II** software is continuously updated and new versions can be downloaded at no charge from the manufacturer's website. To install, execute the **TxConfigIISetup.exe** file and follow the instructions.

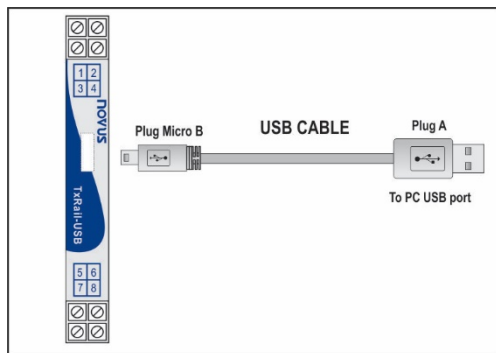

Fig. 1 – USB cable connection

During the setup, the transmitter is powered by the USB, not requiring an external power supply.

The transmitter setup can also be made by connecting it to the loop, using the *loop* power supply. There is no electrical insulation between the transmitter and the communication port (interface), therefore it is not recommended to configure it with the sensor inlet connected to the process. See Fig. 2.

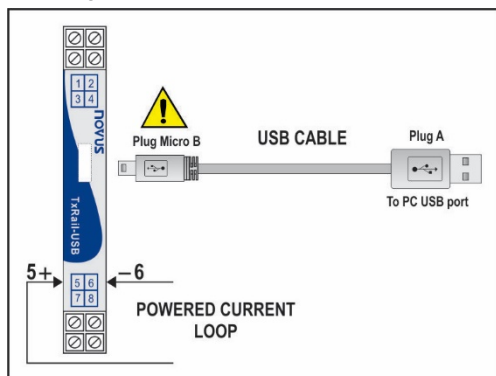
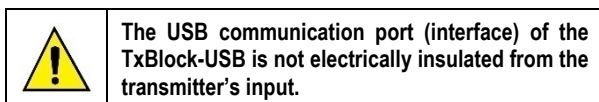

Fig. 2 – USB cable connections – Loop powered

After these connections, the user must run the **TxConfig II** software and, if necessary, consult the *Help* topic to help using the software.



SOFTWARE CONFIGURATION:

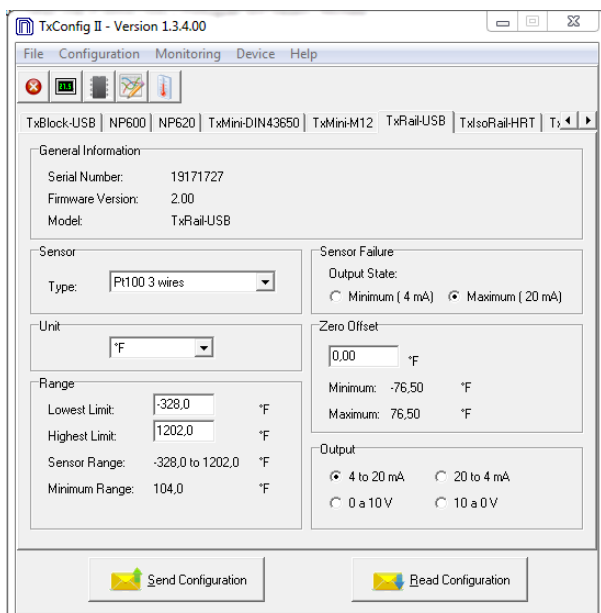

Fig. 3 – TxConfig II software main screen

The fields in the screen mean:

- General Information:** This field shows information that identifying the transmitter. This information should be sent to the manufacturer in an eventual request for technical assistance.
- Sensor:** Select the type of sensor to be used. See Table 1.
- Measuring Range:** Sets de measurement range of the transmitter.

Lower Range Limit: Desired temperature for minimum retransmission value.

Upper Range Limit: Desired temperature for maximum retransmission value.

Sensor Range

The values chosen cannot exceed the **range of sensor** shown in this field. See Table 1 of this manual.

Minimum Range

Do not set a lower band (span) that the **Minimum Range** indicated below in this same field. See Table 1 of this manual.

- Sensor Failure:** It establishes the output behavior, when the transmitter indicates a failure:

Minimum: output current goes to < 3.8 mA or output voltage is 0 V (down-scale), typically used for refrigeration.

Maximum: output current goes to > 20.5 mA or output voltage is 10 V (up-scale), typically used for heating.

- Zero Correction:** It corrects small deviations presented in the transmitter output, for example, when the sensor is replaced.
- Send Configuration:** It applies the new setup. Once sent, the setup will be immediately adopted by the transmitter.
- Read Configuration:** Reads the current setup in the transmitter connected. The screen now presents the current setup that may be changed by the user.

FACTORY SETTING:

- Sensor: Pt100 3-wire, range 0 to 100 °C
- Sensor failure: upscale (maximum).
- 0 °C zero correction.
- Unit: °C;
- Output: 4-20 mA.

MECHANICAL INSTALLATION

The TxRail-USB transmitter is suitable to be installed in 35 mm DIN rail. Vibrations, moisture and extreme temperatures, electro-magnetic interference, high voltage and other interferences can permanently damage the unit, and could cause error in the measured value.

DIMENSIONS:

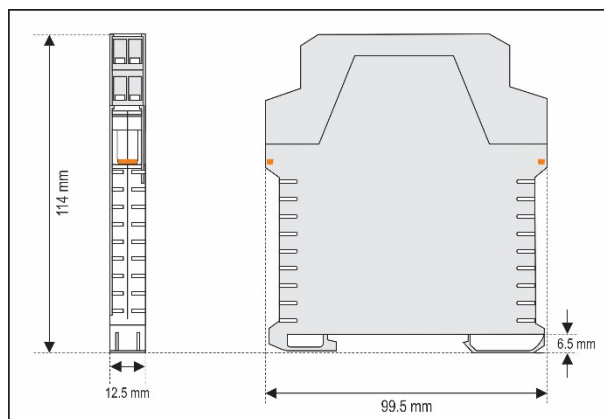

Fig. 4 – Transmitter dimensions

OPENING THE TRANSMITTER:

In order to open the transmitter, you must press the orange lockers located on both sides of the enclosure and pull the frontal cover very carefully, just like shown in Fig. 5.

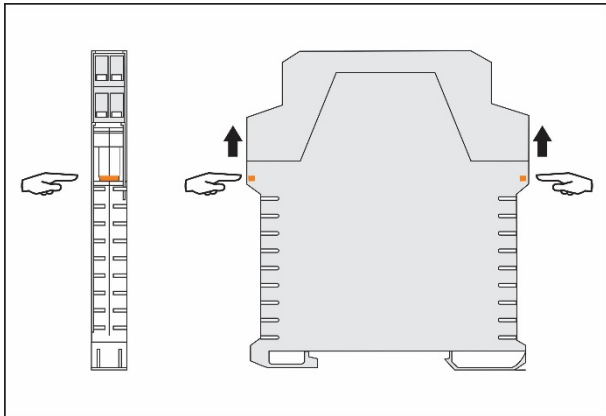

Fig. 5 – Opening the transmitter

ELECTRICAL INSTALLATION

The Fig. 6 shows the electrical connections required. The TxRail-USB wiring for thermocouple, RTD, resistance and voltage are done according figure below.

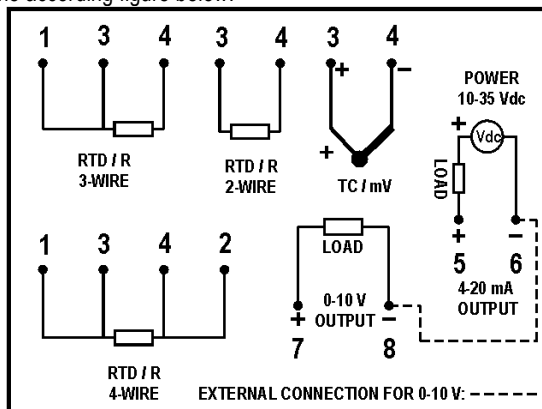

Fig. 6 – TxRail-USB transmitter electrical connections

LOAD represents the 4-20 mA current or the 0-10 V voltage measuring device (indicator, controller, register, etc.).

- Polyamide enclosure.
- Section of the cable used: 0.14 to 1.5 mm²
- Recommended torque in the terminal: 0.8 Nm.

RECOMMENDATIONS FOR INSTALLATION

- Conductors of small electrical signals must be distant from activation and high-tension/current conductors, preferably passing through grounded conduits.
- A specific electrical power supply network should be provided for instruments use only.
- In controlling and monitoring applications, possible consequences of any system failure must be considered in advance.
- RC filters (47R an 100nF, serial) in inductor charges (contactors, solenoids, etc.) are recommended.

ELECTRICAL CONNECTIONS

The figures below show the electrical connections required. The terminals 1, 2, 3 and 4 are dedicated to the sensor connection. **LOAD** represents the 4-20 mA current or 0-10 V voltage measuring device (indicator, controller, recorder, etc.).

PT100/PT1000 2-WIRE / NTC

Note: When the Pt100/Pt1000 2-wire the terminals 1 and 3 must be interconnected, according to the figure below.

To use the Pt100/Pt1000 2-wire, you must configure the Pt100/Pt1000 3-wire option in **TxConfig II**.

The Pt100/Pt1000 wire length **should be less than 30 cm** to maintain the measurement error within specifications (electrical resistance).

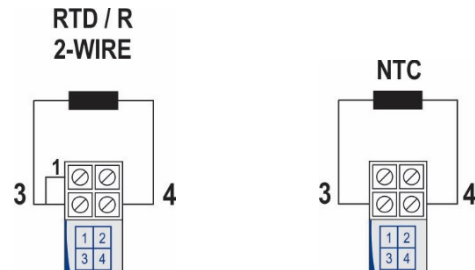

Fig. 7 – Transmitter electrical connections (Pt100/Pt1000 2-wire / NTC)

PT100/PT1000 3-WIRE

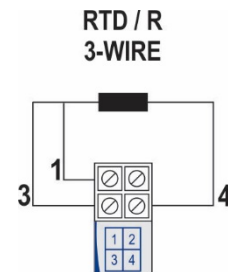

Fig. 8 – Transmitter electrical connections (Pt100/Pt1000 3-wire)

PT100 4-WIRE

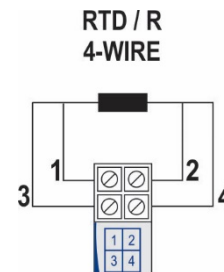

Fig. 9 – Transmitter electrical connections (Pt100 4-wire)

Pt100 3 and 4-wire: For appropriate cable resistance compensation they should be equal for all legs. Maximum wire resistance is 25 Ω per wire leg. Usage of a 3 or 4 wire with conductors of equal length and gauge is recommended.

THERMOCOUPLES

THERMOCOUPLE SENSOR

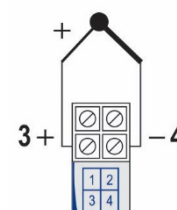

Fig. 10 – Transmitter electrical connections (Thermocouple)

VOLTAGE (0-50 mV / 0-100 mV)**0-50 mV / 0-100 mV**

Fig. 11 – Transmitter electrical connections (0-50 mV / 0-100 mV)

OUTPUTS (0-10 V and 4-20 mA)

Fig. 12 – Transmitter electrical connections (0-10 V and 4-20 mA)

OPERATION

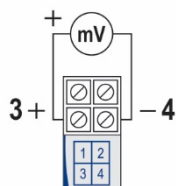
The sensor offset can be changed through the *TxConfig II* software. The USB cable may be connected to the transmitter without causing any measurement errors. See item *Zero Correction* in the chapter **CONFIGURATION** of this manual.

The user must choose the most suitable sensor and range to the process. The chosen range must not exceed the maximum range of measurement defined for the sensor and should not be smaller than the minimum range for the same sensor.

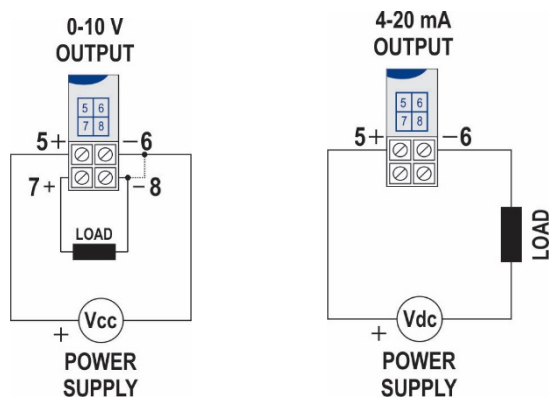
It is important to note that the transmitter accuracy is based on the maximum range of the sensor used, even when a narrower range is programmed. Example:

- The Pt100 sensor in the range 0 to 100 °C and accuracy of 0.12 %, the maximum error will be 1.02 °C (0.12 % de 850 °C);
- The Pt100 sensor in the range 500 to 600 °C and accuracy of 0.19 %, the maximum error will be 1.61 °C (0.19 % of the 850 °C).

Note: When measurements are made at the transmitter, see if the Pt100 excitation current required by the calibrator is compatible with the Pt100 excitation current used in the transmitter: 0.8 mA.

WARRANTY

Warranty conditions are available on our website www.novusautomation.com/warranty.