

DIN Rail Power Supply



0165N-24V30W1AC / 24V 30W 1 Phase (NEC Class 2)



Highlights & Features

- Ultra compact size and galvanic isolation up to 3.0kVac between input to output and input to ground.
- Universal AC input voltage and full power from -10°C to +55°C operation
- Up to 88.0% efficiency @240Vac
- Low earth leakage current < 0.5mA @ 240Vac
- NEC Class 2 / Limited Power Source (LPS) certificate

Safety Standards



CB Certified for worldwide use

Model Number : 0165N-24V30W1AC
Unit Weight : 0.10 kg (0.22 lb)
Dimensions(L x W x D) : 75 x 21 x 89.5 mm
(2.95 x 0.83 x 3.52 inch)

General Description

The ultra-compact and competitively priced Dinkle 0165N DIN rail power supply series is designed for industrial applications requiring highly reliable power supply within a tight space. The 0165N series operates with universal AC input range and offers full power up to 55°C. All models in the series are certified according to IEC/EN/UL 60950-1 Information Technology Equipment (ITE) and UL 508 Industrial Control equipment (ICE). The series is also fully compliant with RoHS Directive 2011/65/EU for environmental protection. NEC Class 2 and Limited Power Source (LPS) approvals are available for this product.

Model Information

0165N DIN Rail Power Supply

Model Number	Input Voltage Range	Rated Output Voltage	Rated Output Current
0165N-24V30W1AC	85-264Vac	24Vdc	1.25A

Model Numbering

0165N	-	24V	30W	1	AC
Power supply		Output Voltage	Output Power	Single Phase	Input Current

Specifications

Input Ratings / Characteristics

Nominal Input Voltage		100-240Vac
Input Voltage Range		85-264Vac
Nominal Input Frequency		50-60Hz
Input Frequency range		47-63Hz
Input Current		< 0.80A @ 115Vac, < 0.40A @ 230Vac
Efficiency at 100% Load	0% Load	< 0.5W @ 115Vac & 230Vac
	100% Load	< 2.5W @ 115Vac & 230Vac
Max Inrush Current (Cold Start)		< 30A @ 115Vac, < 60A @ 230Vac
Leakage Current		< 0.5mA @ 240Vac

All parameters are specified at 25°C ambient and AC input unless otherwise indicated.

Output Ratings / Characteristics*

Nominal Output Voltage	24Vdc
Factory Set Point Tolerance	24Vdc ± 1% (initial set point tolerance from factory)
Output Voltage Adjustment Range	21.6-26.4Vdc
Output Current	1.25A (30W max.)
Output Power	30W
Line Regulation	< 1% typ. (@85-264Vac, 100% Load)
Load Regulation	< 1% typ. (@85-264Vac, 100% Load)
PARD** (20MHz)	< 150mVpp @ > 0°C to 70°C < 500mVpp @ 0°C to -20°C
Rise Time	< 50ms @ nominal input (100% Load)
Start-up Time	< 3,000ms @ 115Vac (100% Load)
	< 1,600ms @ 230Vac (100% Load)
Hold-up Time	> 20ms @ 230Vac (100% Load)
Dynamic Response (Overshoot & Undershoot O/P Voltage)	± 5% @ 85-264Vac input, 0-50% load, 50-100% (Slew Rate:0.1A/μS, 50% duty cycle @ 5Hz to 100Hz)
Start-up with Capacitive Loads	3,000μF Max

* For power de-rating from <-10°C to -20°C, and 55°C to 70°C, see power de-rating on next page "Environment" section.

** PARD is measured with an AC coupling mode, 5cm wires, and in parallel with 0.1μF ceramic capacitor & 47μF electrolytic capacitor.

Mechanical

Case Cover		Plastic
Dimensions (L x W x D)		75 x 21 x 89.5 mm (2.95 x 0.83 x 3.52 inch)
Unit Weight		0.10 kg (0.22 lb)
Indicator		Green LED
Cooling System		Convection
Terminal	Input	3 Pins (Rated 300V / 16A)
	Output	2 Pins (Rated 300V / 16A)
	Input / Output	AWG 26-12
Wire		Standard TS35 DIN Rail in accordance with EN60715
Mounting Rail		Sound Pressure Level (SPL) < 25dBA
Noise (1 Meter from Power Supply)		

Environment

Surrounding Air Temperature	Operating	-20°C to +70°C
	Storage	-40°C to +85°C
Power De-rating		-10°C to -20°C de-rate power by 5% / °C >55C de-rate power by 3.33% / °C
Operating Humidity		5 to 95 % RH (Non-Condensing)
Operating Altitude		0 to 2,000 Meters (6,560 ft.)
Shock Test	Non-Operating	IEC60068-2-27, Half Sine Wave: 50G for a duration of 11ms; 3 times per direction
	Operation	IEC60068-2-27, Half Sine Wave: 10G for a duration of 11ms; 1 shock for X direction
Vibration	Non-Operating	IEC 60068-2-6, Random: 5-500Hz; 2.09Grms, 20min per axis for all X, Y, Z directions
	Operation	IEC 60068-2-6, Random: 10-500Hz; 19.6m/S2 (2G peak); 10min per cycle, 60 min for X direction
Pollution Degree		2

All parameters are specified at 25°C ambient and AC input unless otherwise indicated.

Protections

Overvoltage	< 34.8V, SELV Output, Auto-Recovery
Overload / Overcurrent	110-150% of rated load current, Hiccup Mode, Non-Latching (Auto -Recovery when the fault is removed)
Over Temperature	Auto-Recovery
Short Circuit	Auto-Recovery when the fault is removed
Internal Fuse at L Pin	T3.15A
Degree of Protection	IP20
Protection Against Shock	Class I with PE* connection

*PE: Primary Earth

Reliability Data

MTBF	Telcordia SR-332	> 700,000 hrs. I/P: 100Vac, O/P: 100% load, Ta: 25°C
Expected Cap Life Time		10 years (230Vac, 50% load @ 40°C)

Safety Standards / Directives

Safety Entry Low Voltage		SELV (EN 60950)
Electrical Safety	UL/cUL recognized CB Scheme	UL60950-1, CSA C22.2 No. 60950-1 (File No. E...) IEC60950-1, Limited Power Source (LPS)
Industrial Control Equipment	UL/cUL Listed	UL508 and CSA C22.2 No. 107.1-01 (File No. E...)
CE		In Conformance with EMC Directive 2014/30/EU and Low Voltage Directive 2014/35/EU
Material and Parts		RoHS Directive 2011/65/EU Compliant
Galvanic Isolation	Input to Output	3.0KVac
	Input to Ground	1.5KVac
	Output to Ground	0.5KVac

EMC

Emissions (CE & RE)		Generic Standards: EN 61000-6-3, EN 61000-6-4 CISPR 32, EN 55032, FCC Title 47: Class B
Immunity		Generic Standards: EN55024
Electrostatic Discharge	IEC 61000-4-2	Criteria A ¹⁾ Air Discharge: 8KV (Level 3) Contact Discharge: 8KV (Level 4)
Radiated Field	IEC 61000-4-3	Level 2 Criteria A ¹⁾ 80MHz-1GHz, 10V/M with 1kHz tone / 80% modulated
Electrical Fast Transient / Burst	IEC 61000-4-4	Level 3 Criteria A ¹⁾ 4kV
Surge	IEC 61000-4-5	Level 4 Criteria A ¹⁾ Common Mode ²⁾ : 4kV
Conducted	IEC 61000-4-6	Level 3 Criteria A ¹⁾ 150kHz-80MHz, 10Vrms
Power Frequency Magnetic Fields	IEC 61000-4-8	Criteria A ¹⁾ 1A/Meter
Voltage Dips and Interruptions	IEC 61000-4-11	> 100% dip; 1 cycle (20ms)
Voltage Fluctuation and Flicker		IEC/EN 61000-3-3

1) Criteria A: Normal Performance within the specification limits

2) Asymmetrical: Common mode (Line to earth)

3) Symmetrical: Differential mode (Line to line)

All parameters are specified at 25°C ambient and AC input unless otherwise indicated.

Dimensions

L X W X D : 75 X 21 X 89.5mm [2.95 X 0.83 X 3.52 inch]

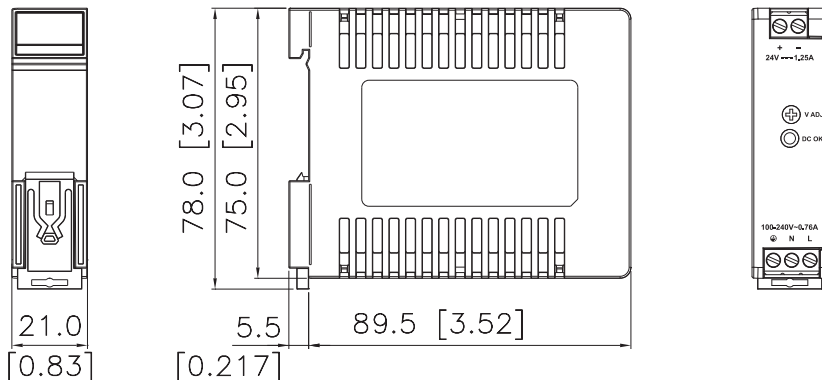

Block Diagram

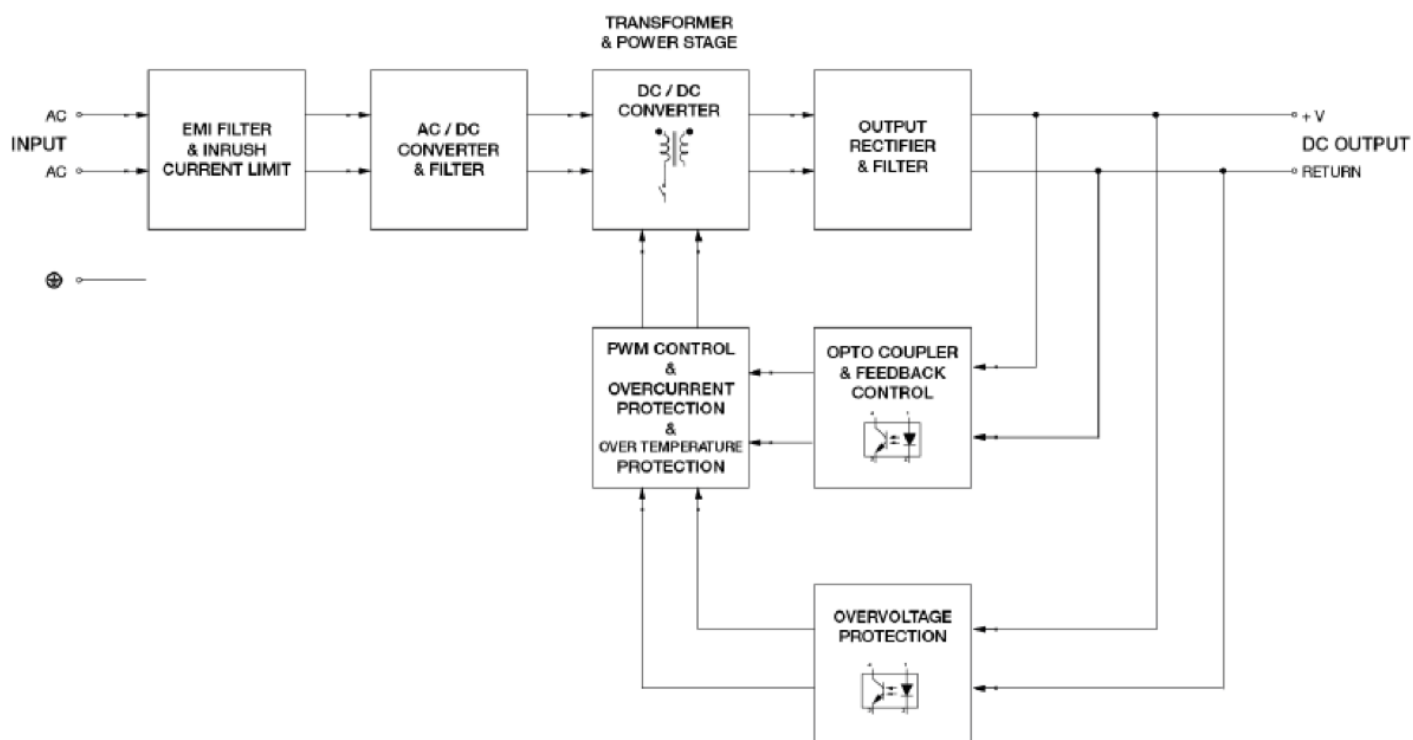

Device Description

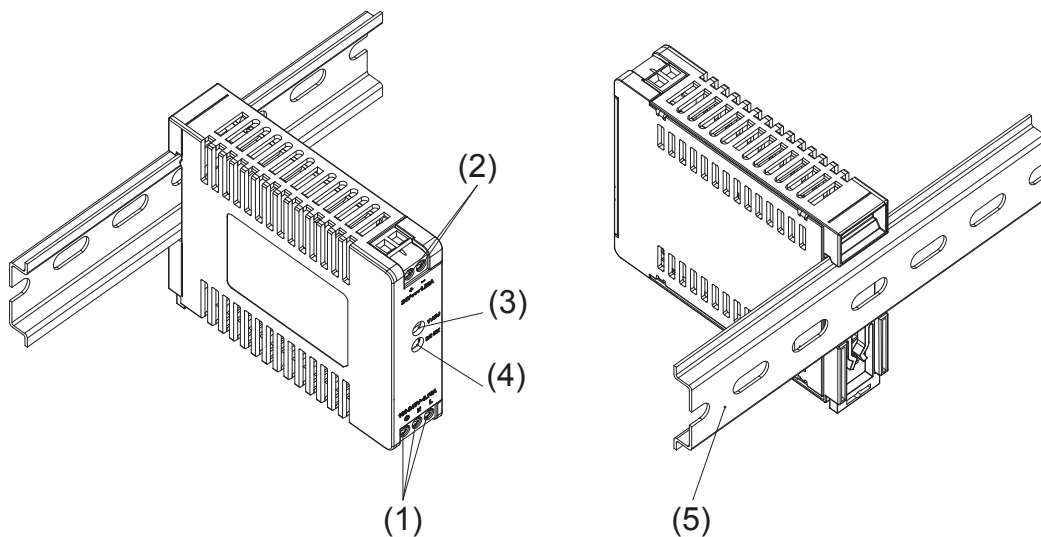

- 1) Input terminal block connector
- 2) Output terminal block connector
- 3) DC voltage adjustment potentiometer
- 4) DC OK LED (Green)
- 5) Universal mounting system

Assembly & Installation

The power supply unit (PSU) can be mounted on 35mm (1.38 inch) DIN rails in accordance with EN60715. The device should be installed with input terminal block at the bottom.

Each device is delivered ready to install.

Mounting

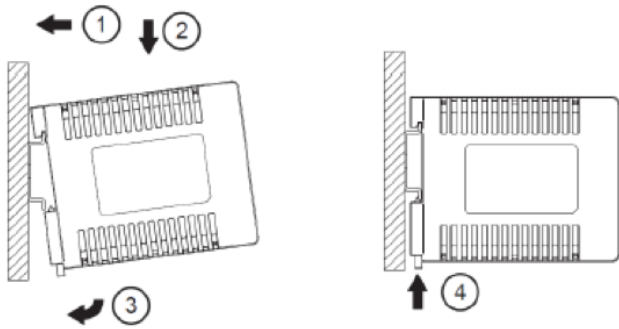

Fig. 2.1 Mounting

Snap on the DIN rail as shown in Fig. 2.1:

1. Tilt the unit upwards and insert it onto the DIN rail.
2. Push downwards until stopped.
3. Press against the bottom front side for locking.
4. Shake the unit slightly to ensure that it is secured.

Dismounting

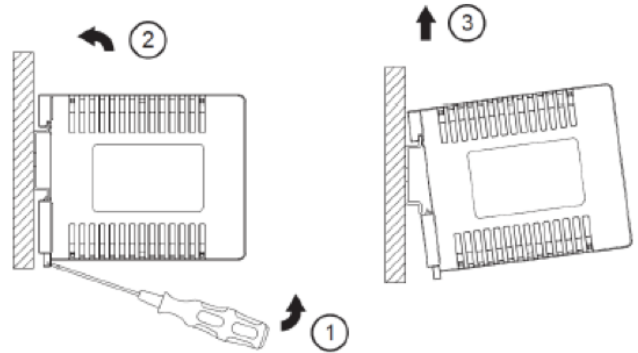

Fig. 2.2 Dismounting

To uninstall, pull or slide down the latch with screw driver as shown in Fig. 2.2. Then slide the power supply unit (PSU) in the opposite direction, release the latch and pull out the power supply unit (PSU) from the rail.