

DIN Rail Power Supply



0165N-24V120W1AC / 24V 120W 1 Phase (NEC Class 2)



Highlights & Features

- Universal AC input voltage range
- Built-in constant current circuit for reactive loads
- Up to 88.0% efficiency
- Up to 88.1% efficiency
- Up to 88.2% efficiency
- Up to 88.3% efficiency
- Up to 88.4% efficiency
- Up to 88.5% efficiency
- Up to 88.6% efficiency

Safety Standards



CB Certified for worldwide use

Model Number : 0165N-24V120W1AC

Unit Weight : 0.54 kg (1.19 lb)

Dimensions(L x W x D) : 123.6 x 40 x 117.6 mm
(4.86 x 1.57 x 4.46 inch)

General Description

This Dinkle DIN rail power supply is designed for cost sensitive users who need to fulfill essential features needed for many general industrial applications, without compromising on quality and reliability. The convection-cooled series will operate between -20°C to 70°C, with full rated power available from -10°C to +50°C at 230Vac. The overcurrent protection is designed to operate in constant current mode, which makes the series suitable for inductive and capacitive load applications. The product is certified according to safety standards IEC/EN/UL 60950-1 for Information Technology Equipment (ITE) and UL508 for Industrial Control Equipment (ICE). Electromagnetic radiated and conducted emissions are compliant to EN 55032, Class B; and, the product is fully compliant for environmental protection requirement per RoHS Directive 2011/65/EU.

Model Information

0165N DIN Rail Power Supply

Model Number	Input Voltage Range	Rated Output Voltage	Rated Output Current
0165N-24V120W1AC	85-264Vac (120-375Vdc)	24Vdc	5.00A

Model Numbering

0165N	-	24V	120W	1	AC
Power supply		Output Voltage	Output Power	Single Phase	Input Current

Specifications

Input Ratings / Characteristics

Nominal Input Voltage		100-240Vac
Input Voltage Range		85-264Vac
Nominal Input Frequency		50-60Hz
Input Frequency range		47-63Hz
DC Input Voltage Range*		120-375Vdc
Input Current		2.2A typ. @ 115Vac, 1.2A typ. @ 230Vac
Efficiency at 100% Load		85% typ. @ 115Vac, 88% typ. @ 230Vac
Max Power Dissipation	0% load	0.65W @ 115Vac & 230Vac
	100% load	13.3W @ 115Vac & 230Vac
Max Inrush Current (Cold Start)		20A typ. @ 115Vac, 40A typ. @ 230Vac
Leakage Current		< 0.25mA @ 264Vac

*Fulfills test conditions for DC input. Safety approval for DC input can be obtained upon request.

All parameters are specified at 25°C ambient and AC input unless otherwise indicated.

Output Ratings / Characteristics*

Nominal Output Voltage		24Vdc
Factory Set Point Tolerance		24Vdc \pm 2%
Output Voltage Adjustment Range		22-28Vdc
Output Current		5.00A
Output Power		120W
Line Regulation		< 0.5% (@85-264Vac, 100% Load)
Load Regulation		< 1% (0-100% Load)
PARD** (20MHz)		< 120mVpp @ > -10°C to +70°C
		< 240mVpp @ \leq -10°C to -20°C
Rise Time		30ms typ. @ nominal input (100% Load)
Start-up Time		200ms typ. @ 115Vac & 230Vac (100% Load)
Hold-up Time		20ms typ. @ 115Vac & 90ms typ. @ 230Vac (100% Load)
Dynamic Response (Overshoot & Undershoot O/P Voltage)		\pm 10% @ 85-264Vac input, 0-100% load (Slew Rate: 0.1A/ μ S) 8,000 μ F Max / Test Report: 5,000 μ F
Start-up with Capacitive Loads		8,000 μ F Max
Functionan	DC OK Relay Contact	30V / 1A The relay contact are nomally "ON" (closed) when the output (Vout) is greater than 90% of its rated value.

** For power de-rating from -10°C to -20°C, and 40°C to 70°C @ 115Vac & 50°C to 70°C @ 230Vac, and Vin < 100Vac, see power de-rating on next page "Environment" section.

*** PARD is measured with an AC coupling mode, 5cm wires, and in parallel with 0.1 μ F ceramic capacitor & 47 μ F electrolytic capacitor.

Mechanical

Case Cover		Plastic SGCC/Aluminium
Dimensions (L x W x D)		123.6 x 40 x 117.6 mm (4.86 x 1.57 x 4.62 inch)
Unit Weight		0.54 kg (1.19 lb)
Indicator		Green LED (DC OK)
Cooling System		Convection
Terminal	Input / Output	3 Pins (Rated 600V / 35A) / 4 Pins (Rated 300V / 28A)
Wire	Input / Output	AWG 18-8 / AWG 24-12
Mounting Rail		Standard TS35 DIN Rail in accordance with EN60715
Noise (1 Meter from Power Supply)		Sound Pressure Level (SPL) < 25dBA

Environment

Surrounding Air Temperature	Operating	-20°C to +70°C
	Storage	-40°C to +85°C
Power De-rating	Temperature	-10°C to -20°C de-rate power by 2% / °C > 40°C de-rate power by 1.67% / °C @115Vac > 50°C de-rate power by 2.5% / °C @230Vac
	Input Voltage	< 100Vac de-rate power by 1% / Vac
Operating Humidity		5 to 95 % RH (Non-Condensing)
Operating Altitude		0 to 5,000 Meters (16,400 ft.)
Shock Test	Non-Operating	IEC60068-2-27, 27, Half Sine Wave: 50G for a duration of 11ms; 3 times per direction, 9 times in total
	Operation	IEC60068-2-27, 27, Half Sine Wave: 10G for a duration IEC60068-2-27, 27, Half Sine Wave: 10G for a duration of 11ms; 1 time in X axis
Vibration	Non-Operating	IEC 60068-2-6, Random: 5-500Hz; 2.09Grms, 20min per axis for all X, Y, Z directions
	Operation	IEC 60068-2-6, Sine Wave: 10Hz to 500Hz; 19.6m/S ² (2G peak); displacement of 0.35mm; 10min per cycle, 60 min for X direction
Pollution Degree		2

Protections

Overvoltage	28.5V-35.2V, SELV Output, Latch Mode
Overload / Overcurrent	105-150% of rated load current, constantContinuous current
Over Temperature	Latch Mode
Short Circuit	Hiccup Mode, Non-Latching (Auto-recovery when the fault is removed)
Internal Fuse at L Pin	T4A / 250VTBD
Degree of Protection	IP20
Protection Against Shock	Class I with PE* connection

* PE: Primary Earth

All parameters are specified at 25°C ambient and AC input unless otherwise indicated.

Reliability Data

MTBF	Telcordia SR-332	> 700,000 hrs. I/P: 100Vac, O/P: 100% load, Ta: 25°C
Expected Cap Life Time		10 years (115Vac & 230Vac, 50% load @ 40°C)

Safety Standards / Directives

Safety Entry Low Voltage		SELV (EN 60950)
Electrical Safety	CB scheme	IEC60950-1
Industrial Control Equipment	UL/cUL Listed	UL508 and CSA C22.2 No. 107.1-01 (File No. E...)
CE		In Conformance with EMC Directive 2014/30/EU and Low Voltage Directive 2014/35/EU
Material and Parts		RoHS Directive 2011/65/EU Compliant
Galvanic Isolation	Input to Output	3.0KVac
	Input to Ground	2.0KVac
	Output to Ground	0.5KVac

EMC

Emissions (CE & RE)	Generic Standards: EN 61000-6-3, EN 61000-6-4 CISPR 32, EN 55032, FCC Title 47: Class B GB9254.1
Component Power Supply for General Use	EN61204-3
Immunity	Generic Standards: EN61000-6-1, EN61000-6-2, EN55024

EMC

Electrostatic Discharge	IEC 61000-4-2	Level 4 Criteria A ¹⁾ Air Discharge: 15KV Contact Discharge: 8KV		
Radiated Field	IEC 61000-4-3	Level 3 Criteria A ¹⁾ 80MHz-1GHz, 10V/M with 1kHz tone / 80% modulation 1.4GHz-2GHz, 3V/M with 1kHz tone / 80% modulation 2GHz-2.7GHz, 1V/M with 1kHz tone / 80% modulation		
Electrical Fast Transient / Burst	IEC 61000-4-4	Level 3 Criteria A ¹⁾ 2kV		
Surge	IEC 61000-4-5	Level 4 Criteria A ¹⁾ Common Mode ³⁾ : 4kV Differential Mode ⁴⁾ : 2kV		
Conducted	IEC 61000-4-6	Level 3 Criteria A ¹⁾ 150kHz-80MHz, 10Vrms		
Power Frequency Magnetic Fields	IEC 61000-4-8	Level 4 Criteria A ¹⁾ 30A/m		
Voltage Dips and Interruptions	IEC 61000-4-11	0% of 100Vac, 20ms	Criteria A ¹⁾	
		40% of 100Vac, 200ms	Criteria B ²⁾	
		70% of 100Vac, 500ms	Criteria A ¹⁾	
		0% of 100Vac, 5,000ms	Criteria B ²⁾	
		0% of 240Vac, 20ms	Criteria A ¹⁾	
		40% of 240Vac, 200ms	Criteria A ¹⁾	
		70% of 240Vac, 500ms	Criteria A ¹⁾	
		0% of 240Vac, 50,00ms	Criteria B ²⁾	
Low Energy Pulse Test (Ring Wave)	IEC 61000-4-12	Level 3 Criteria A ¹⁾ Common Mode ³⁾ : 2KV Differential Mode ⁴⁾ : 1KV		
Harmonic Current Emission	IEC/EN 61000-3-2, Class A; GB17625.1			
Voltage Fluctuation and Flicker	IEC/EN 61000-3-3			
Voltage Sag Immunity SEMI F47-0706	80% of 200Vac	160Vac, 1000ms	Criteria A ¹⁾	
	70% of 200Vac	140Vac, 500ms	Criteria A ¹⁾	
	50% of 200Vac	100Vac, 200ms	Criteria A ¹⁾	

1) Criteria A: Normal Performance within the specification limits

2) Criteria B: Temporary degradation or loss of function which is self-recoverable

3) Asymmetrical: Common mode (Line to earth)

4) Symmetrical: Differential mode (Line to line)

All parameters are specified at 25°C ambient and AC input unless otherwise indicated.

Dimensions

L X W X D : 123.6 X 40 X 117.6mm [4.86 X 1.57 X 4.62 inch]
DRL-24V120W1AA

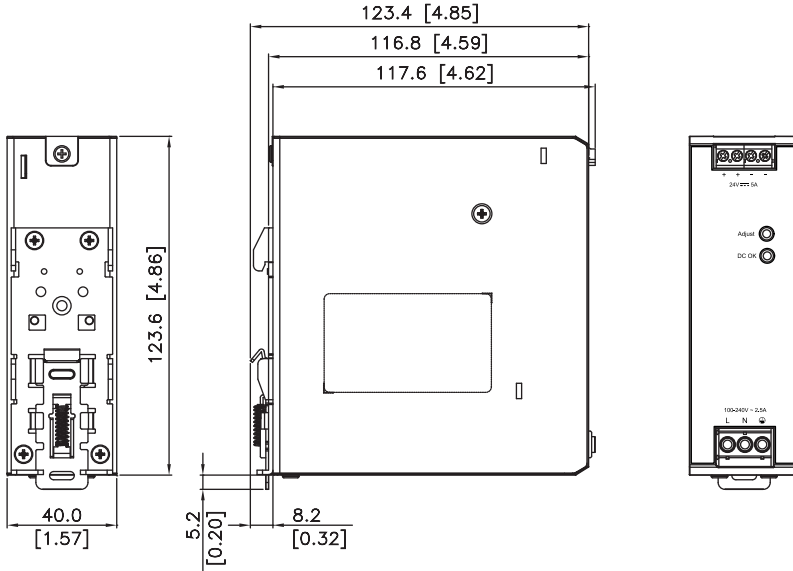

Block Diagram

DRL-24V120W1AA

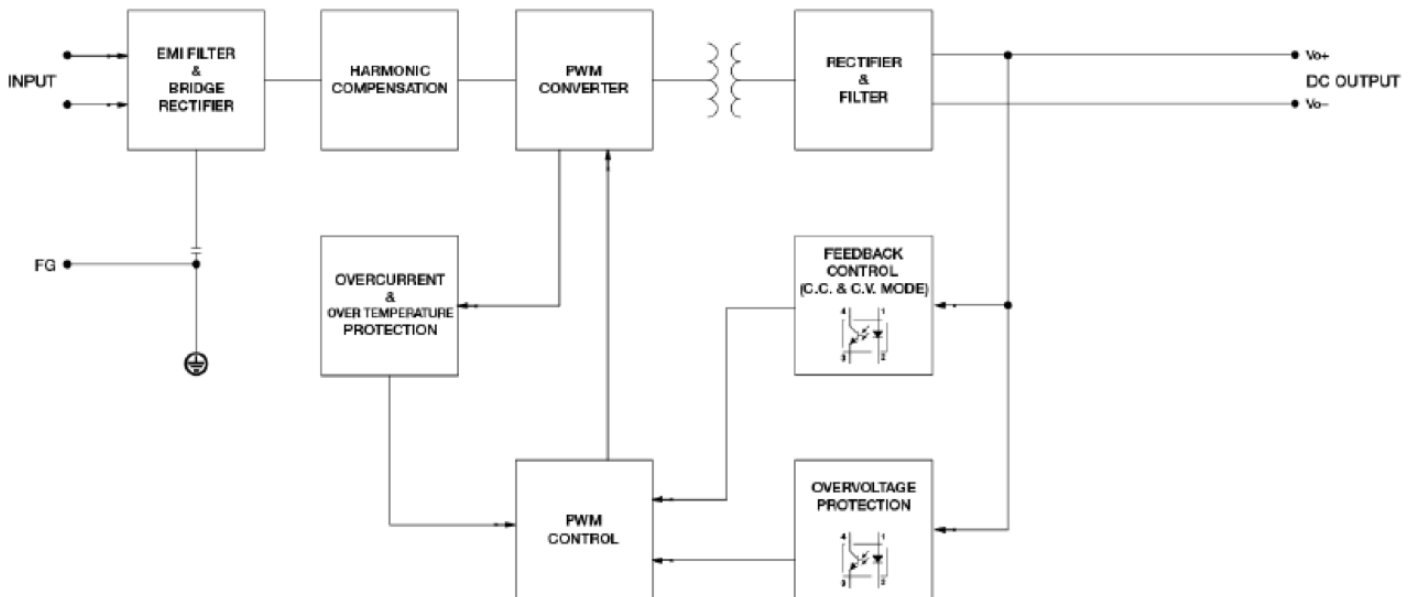

Device Description

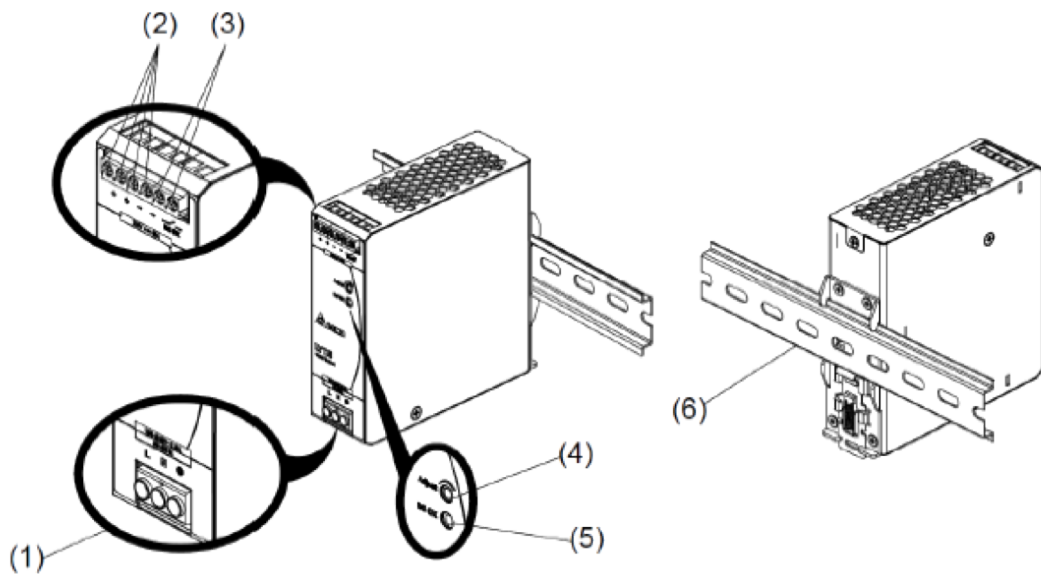

- 1) Input terminal block connector
- 2) Output terminal block connector
- 3) DC OK relay contact (for DRL-24V-120W1AS only)
- 4) DC voltage adjustment potentiometer
- 5) DC OK LED (Green)
- 6) Universal mounting rail system

Assembly & Installation

The power supply unit (PSU) can be mounted on 35mm DIN rails in accordance with EN60715. The device should be installed with input terminal block at the bottom.

Each device is delivered ready to install.

Mounting

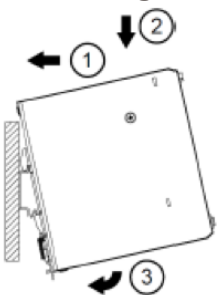

Fig. 2.1 Mounting

Snap on the DIN rail as shown in Fig. 2.1 :

1. Tilt the unit upwards and insert in onto the DIN rail.
2. Push downwards until stopped.
3. Press against the bottom front side for locking.
4. Shake the until slightly to endure that it is secured.

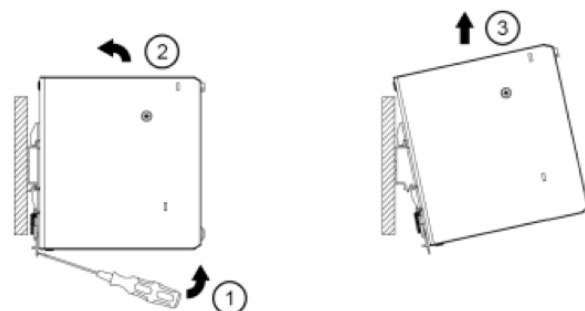

Fig. 2.1 Dismounting

To uninstall, pull or slide down the latch with screw driver as shown in fig. 2.2. Then slide the power supply unit (PSU) in the opposite direction, release the latch and pull out the power supply unit (PSU) from the rail.

In accordance to EN 60950 / UL 60950, flexible cables require ferrules.

Use appropriate copper cables designed to sustain operating temperature of at least 60°C / 75°C or more to fulfill UL requirements.