

SmartBlock I/O Module

HE579MIX102 Isolated

6 Relay, 12 DC Inputs, 4 Analog Inputs

1. Specifications

Digital DC Inputs	
Inputs per Module	12
Commons per Module	2
Input Voltage Range	12VDC / 24VDC
Absolute Max. Voltage	35VDC Max.
Input Impedance	10k Ω
Isolation	500V
Current Max Upper Threshold	0.7mA
Current Min Lower Threshold	0.2mA
Voltage Max Upper Threshold	8VDC
Voltage Min Lower Threshold	3VDC

Digital Relay Outputs	
Outputs per Module	6 relay
Commons per Module	6
Max. Output Current per Relay	3A at 250VAC, resistive
Max. Total Output Current	5A continuous
Max. Output Voltage	275VAC, 30VDC
Response Time	Comm Time + 10ms
Max. Switched Power	1250VA, 150W
Contact Isolation to XLE ground	1000VAC
Max. Voltage Drop at Rated Current	0.5V
Expected Life (See Derating section for chart.)	No load: 5,000,000 Rated load: 100,000
Max. Switching Rate	300 CPM at no load 20 CPM at rated load
Type	Mechanical Contact

Analog Inputs High Resolution	
Number of Channels	4
Input Ranges	0-10VDC 0-5VDC 0 to 20mA 4 - 20mA
Safe input voltage range	mA: -0.5 to 5V V: -0.5 to +30V
Isolation	500V
Input Impedance	<u>Current Mode:</u> 55 Ω <u>Voltage Mode:</u> 1M Ω
Nominal Resolution	16 Bits
%AI full scale	32,000 counts
Max. Over-Current	35mA
Max. Error at 25°C (excluding zero)	0.1%
Additional error for temperatures other than 25°C	0.00000116%/°C
Filtering	16Hz hash (noise) filter 1-128 scan digital running average filter

General Specifications	
Voltage Input	10-30VDC
Relative Humidity	5 to 95% Non-condensing
Required Power (Steady State)	2 W (80mA @ 24VDC)
Required Power (Inrush)	DC Switched: 12A 50 μ s AC Switched: 120mA 10ms
Operating Temperature	0° to 60°C
Weight	12 oz. / 340g

2. Dimensions and Installation

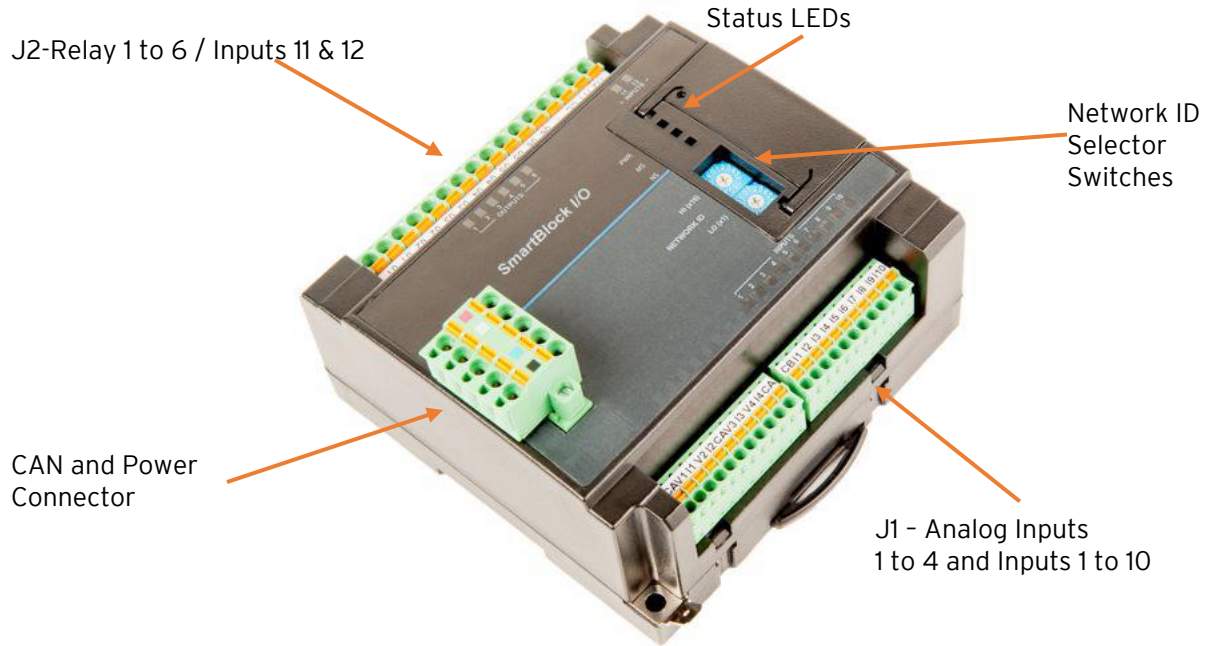

Dimensions



Network, Power, and Grounding:

A single 5-pin connector is used to make both a network connection and power input. A quality class 2 power supply should be used for this product. If the power is run with the network cable, care must be taken such that the voltage does not drop below the lower supply limit on longer runs.

A quality earth ground is required for safe and proper operation. The best ground is achieved by screwing the lower left grounding location into a grounded back plate. Alternately, a ground can be connected to the spade lug.

Please see Horner manual MAN0799 for details on CAN wiring.

3 WIRING

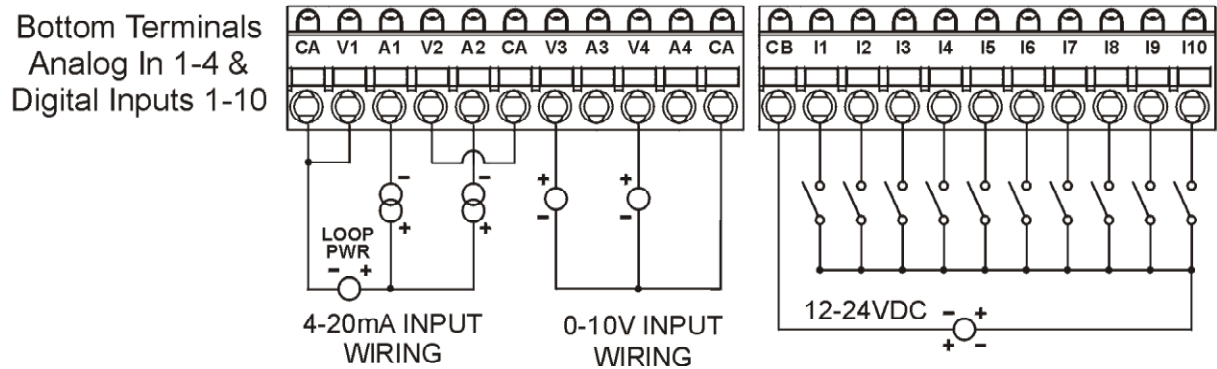
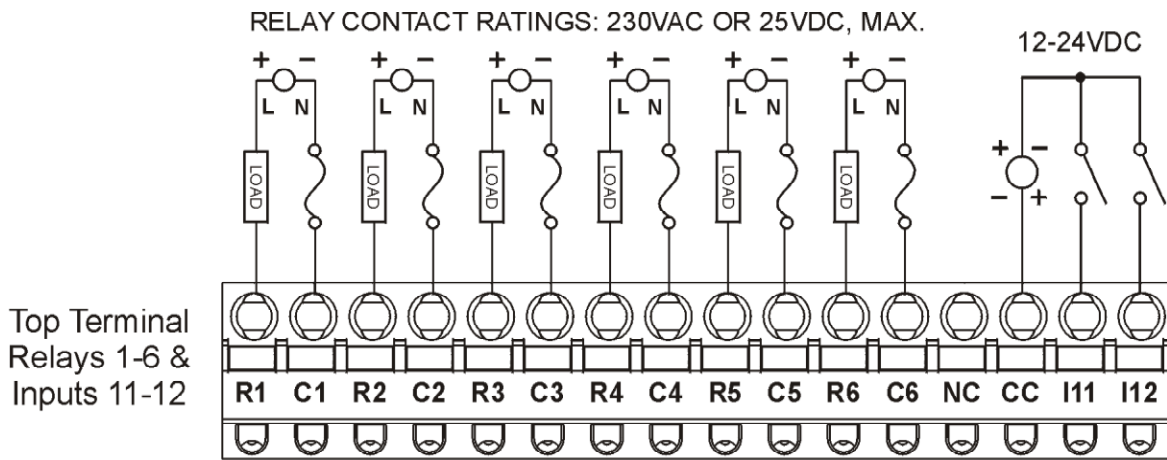

4 CONFIGURATION

For most applications the I/O scanner built into Cscope and the OCS firmware will provide a fast, robust and easy to use method to configure and scan the SmartBlock I/O. For advanced operations such as on-the-fly changes to the input type please see the following chapter on network data and the SmartStix and SmartBlock programming guide.

To configure SmartBlock I/O from Cscope open the Hardware Configuration dialog from the Controller | Hardware Configuration menu. Select the option for CsCAN I/O, then click Add. Select the SmartBlock Tab and select the device to be configured.

Below is the configuration for MIX102 device.

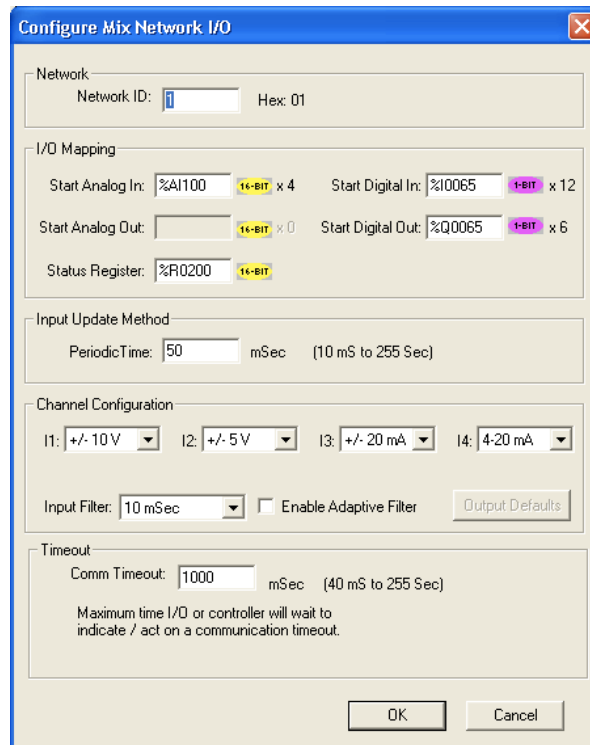

Network ID - This should match the ID of the rotary switch on the SmartBlock unit and should be unique to the network.

I/O Mapping - These registers define how the OCS controller registers are mapped to the data to and from the SmartBlock I/O. These registers do not have to match the I/O types typically used for I/O such as %AI, Q... Any standard controller registers may be used such as %R, %T and %M.

Input Update Method - This defines how often analog data is sent from the SmartBlock to the CsCAN network. Digital data is transmitted on change of state.

Channel Configuration - This selects how each analog channel is configured including filtering.

Timeout - This sets the time a controller will wait before assuming the host OCS is off-line.

5 NETWORK DATA

Consumed Digital Data - This data is sent from the controller to the SmartBlock. *For typical applications the I/O configuration setup in Cscape will automatically populate this data.* For more advanced applications you may use NetPut functions to write this data. Please see the advanced programming guide MAN0880 for more details.

Bit	Description	
1-4	Mode Bit 1 bit per channel	0 = Voltage Mode 1 = Current mode
13-16	Filter	See programming Guide
17-20	Scale Bit 1 bit per channel	0 = $\pm 10V$ or $\pm 20mA$ 1 = $\pm 5V$ or 4-20mA
81-86	Digital Outputs	Bits that control the relay outputs
97-102	Digital Stop Overrides	Bits that allow override of outputs on stop
113-118	Digital Stop Defaults	Values for override on stop

Produced Digital Data - This data is sent from the SmartBlock to the controller. *Normally this data is mapped into specific registers in the I/O configuration in Cscape.* For advanced applications NetGet functions can be used to obtain this data. Since this data is broadcast to all controllers on the network additional controllers can use NetGet functions to obtain this data as well.

Bit	Description
1-12	Digital Inputs - Data from the digital inputs
33-48	Status and Diagnostic Data
49-56	Firmware Version
57-64	Device Class - 60 for the MIX102

Produced Analog Data - This data is sent from the SmartBlock to the controller. *Normally this data is mapped into specific registers in the I/O configuration in Cscape.* For advanced applications NetGet functions can be used to obtain this data. Since this data is broadcast to all controllers on the network additional controllers can use NetGet functions to obtain this data as well.

Word	Function	
Word 1	INT	Analog Input 1 Data
Word 2	INT	Analog Input 2 Data
Word 3	INT	Analog Input 3 Data
Word 4	INT	Analog Input 4 Data

6 INSTALLATION / SAFETY

Warning: Remove power from the OCS controller, CAN port, and any peripheral equipment connected to this local system before adding or replacing this or any module

- a) All applicable codes and standards should be followed in the installation of this product.
- b) Shielded, twisted-pair wiring should be used for best performance.
- c) Shields are to be terminated to frame ground.
- d) In severe applications, shields should be tied directly to the ground block within the panel.
- e) Ungrounded thermocouple sensors are preferred due to their isolated electrical characteristics
- f) Interposing terminal strips between the sensor and the module can cause errors due to cold junction effect.
- g) If interposing terminal strips must be used, use specially constructed terminal blocks, which match the material characteristics of the thermocouple sensor.
- h) Horner thermocouple input modules use a high impedance differential circuit to support the use of grounded or ungrounded thermocouples. For grounded thermocouples, the specified **Common Mode Range** allows for ground potential differences between the machine ground and the PLC ground within that range. For ungrounded or floating thermocouples the high impedance inputs are subject to common mode noise pickup. For noisy environments it is recommended that one side of all ungrounded thermocouples be grounded near the PLC. This does not affect open thermocouple detection or measurement accuracy and reduces the effect of common mode noise if present. This PLC side ground connection must not be used with grounded thermocouples or accuracy will be affected. Any thermocouple should be grounded in one place at most.

When found on the product, the following symbols specify:



Warning: Consult user documentation.



Warning: Electrical Shock Hazard.

WARNING: To avoid the risk of electric shock or burns, always connect the safety (or earth) ground before making any other connections.

WARNING: To reduce the risk of fire, electrical shock, or physical injury it is strongly recommended to fuse the voltage measurement inputs. Be sure to locate fuses as close to the source as possible.

WARNING: Replace fuse with the same type and rating to provide protection against risk of fire and shock hazards.

WARNING: In the event of repeated failure, do not replace the fuse again as a repeated failure indicates a defective condition that will not clear by replacing the fuse.

WARNING: Only qualified electrical personnel familiar with the construction and operation of this equipment and the hazards involved should install, adjust, operate, or service this equipment. Read and understand this manual and other applicable manuals in their entirety before proceeding. Failure to observe this precaution could result in severe bodily injury or loss of life.

- All applicable codes and standards need to be followed in the installation of this product.
- For I/O wiring (discrete), use the following wire type or equivalent: Belden 9918, 18 AWG or larger.

Adhere to the following safety precautions whenever any type of connection is made to the module.

- Connect the green safety (earth) ground first before making any other connections.
- When connecting to electric circuits or pulse-initiating equipment, open their related breakers. Do not make connections to live power lines.
- Make connections to the module first; then connect to the circuit to be monitored.
- Route power wires in a safe manner in accordance with good practice and local codes.
- Wear proper personal protective equipment including safety glasses and insulated gloves when making connections to power circuits.
- Ensure hands, shoes, and floor are dry before making any connection to a power line.
- Make sure the unit is turned OFF before making connection to terminals. Make sure all circuits are de-energized before making connections.
- Before each use, inspect all cables for breaks or cracks in the insulation. Replace immediately if defective.

7 TECHNICAL SUPPORT

North America: Tel: 317 916-4274 Fax: 317 639-4279 Web: http://www.hornerautomation.com Email: techspt@heapg.com	Europe: Tel: +353-21-4321266 Fax: +353-21-4321826 Web: http://www.horner-apg.com Email: tech.support@horner-apg.com
--	---

Cscape, SmartStix, and CsCAN are trademarks of Horner APG. This information is subject to change without notice.