



SmartMod RTD Input Module HE359RTD100

0.1°C or 0.1 Ω Resolution



1 Specifications

RTD100		RTD100	
Number of Channels	4	Conversion Time (PLC Update Rate)	Determined by Communications w/OCS
Input Ranges	RTD Pt-100, Ni-100, Pt-1000, & Ni-1000, 0-2000 Ω, 0-500 Ω (PT, .00385)	Terminal Type	Screw Type, Removable
Resolution	0.1°C or 0.1 Ω	Storage Temp.	-40° to 85°C
RTD Excitation Current	350 μA, typical	Operating Temp.	-10° to 60°C
Accuracy	+/-0.1% of full scale	Relative Humidity	0 to 90% Non-condensing
External Power Supply Voltage	10-30 VDC	Dimensions W x H x D	17.5 mm x 100 mm x 120 mm 0.69" x 3.94" x 4.72"
Required Power (Steady State)	30 mA @ 24VDC, typical	Weight	150 g (6 oz.)
Required Power (Inrush)	Negligible	Communications	Modbus/RTU (binary) RS-485 half duplex
Isolation	2000 VAC for 60 seconds (Input/Power & Input/Comms)	Factory Default Communications Parameters	38400 Bd, N, 8, 1, no h/s Default Modbus ID 1
CE & UL Compliance	https://hornerautomation.com/certifications/ http://horner-apg.com/en/support/certification.aspx	Supported Modbus Commands	1,2,3,4,5,6,8, 15,16

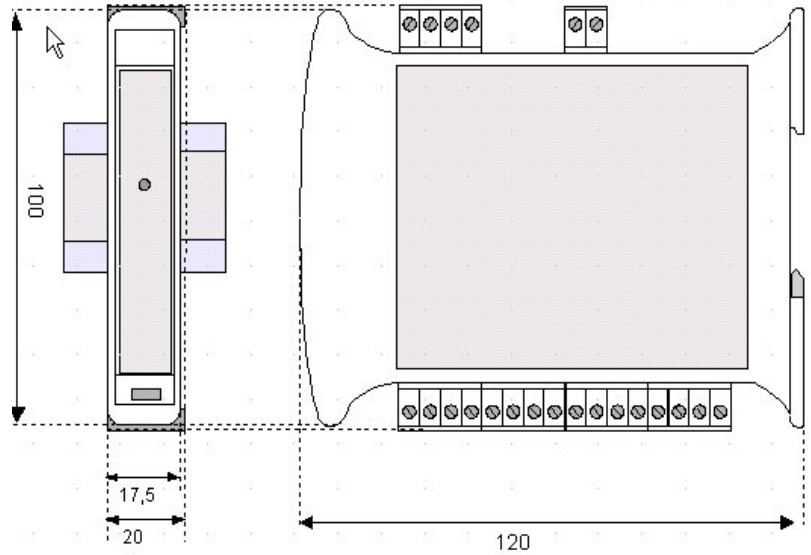

Dimensions in inches are 0.69" W x 3.95" H x 4.72" D
Note: Number of I/O terminal connections varies from model to model.

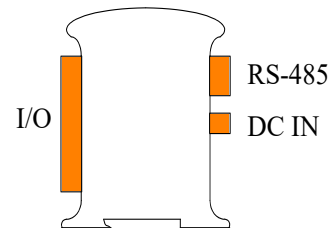

2. Wiring - I/O

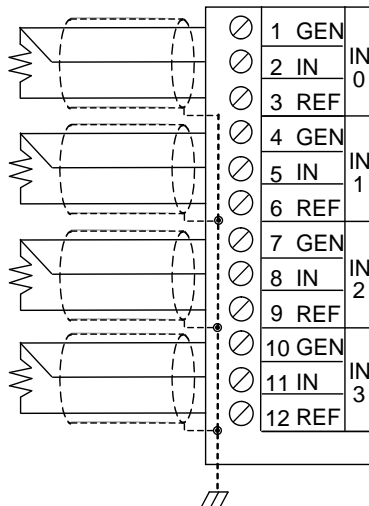

Pin #	RTD100		Pin #	RTD100	
1	GEN	IN 0	7	GEN	IN 2
2	IN		8	IN	
3	REF		9	REF	
4	GEN	IN 1	10	GEN	IN 3
5	IN		11	IN	
6	REF		12	REF	

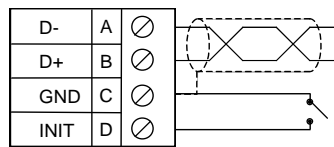

Wiring RS-485

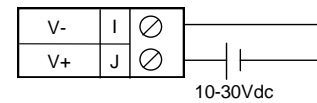

Wiring DC IN

Notes:

Both ends of the RS-485 network should be terminated with a 100 Ω, 1/4 W, 1% resistor. Many OCS controllers feature dip switches or jumpers which enable appropriate termination if the OCS is located on a network end.

3. Init Default Setup

Communication parameters will be set to INIT default after performing the following procedure:

1. Install jumper between INIT and GND terminals of the RS-485 port.
2. Apply power to SmartMod unit.
3. Read parameter words to see current parameters.
4. Write changes if necessary.

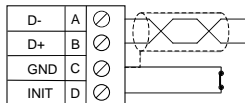

The INIT Default RS485 Settings Are:

Modbus ID = 1
 Baud rate = 9600
 Parity = None
 Stop Bits = 1
 Data Bits = 8
 No handshake

Note: There are 2 types of default settings possible:
 1. Factory default as described in section 1 (Specifications)
 2. Default after INIT as described in section 3 (INIT Default Setup)

4. Configuration DATA

SmartMod Configuration settings are mapped into Modbus Register space. This configuration data may be modified with any Modbus/RTU Master device. For convenience, Horner APG has developed a variety of Cscape application files which allow an OCS to act as a SmartMod configuration device. Initial configuration of SmartMod module should be done on an individual basis, since all modules come from the factory with a default Modbus ID of 1. Once each module on the network has its own unique Modbus ID, further configuration adjustments can be made with the entire network powered.

All configuration parameters listed below (except 40012 Channel Enable) are stored in EPROM. This means they should not be constantly rewritten.

Configuration Parameters – Registers 40001 through 40013				
Modbus Register	Description	Min	Max	Default
40001-40005	Reserved			
40006	Communications Parameters	See Table		9600 bps, N, 8, 1, RTU Mode
40007	Modbus ID	1	255	1
40008	Rx/Tx Delay (in 2 ms steps)	0	255	0 ms
40009	Watchdog Timer (in 0.5 s steps)	0	255	10 (5 s)
40010	Modbus Coil Data	Not Configuration Data *See I/O Data		
40011	Input Type	See Table	23 (RTD Pt-100 Type)	
40012	Channel Enable	See Table	255 (All Channels enabled)	
40013	Reserved			

Register 40006 (Communications Parameters) Bit Definition							
Bits 7-15	Bit 6	Bit 5	Bit 4	Bit 3	Bit 2	Bit 1	Bit 0
Unused	Mode	Parity		Data Bits	Baud Rate		
0 = ASCII Mode	0	Value	Meaning	0 = 7 Data Bits	Value	Meaning	
		0	Mark		0	1200 Bd	
	1	1	Even	1 = 8 Data Bits	1	2400 Bd	
		2	Odd		2	4800 Bd	
	3	3	Space	5-7	3	9600 Bd	
		4			4	19200 Bd	
1 = RTU Mode					38400 B-*d		

NOTE:
 Data bits number is ignored, in ASCII mode it is fixed at 7 and in RTU mode it is fixed to 8. In RTU mode the parity bit is ignored (parity is fixed at NONE).

Register 40010 (Mirror of Coil Data) Bit Definition			
Bit 3-15	Bit 2	Bit 1	Bit 0
Unused	Power-up Event (Coil 11)	Watchdog Event (Coil 10)	Watchdog Enabled (Coil 9)
	0 = Disable Input		
	1 = Enable Input		

Register 40011 (Input Type) Value Definition	
Value	Input Type
7	0-2000 Ω Resistance
8	0-500 Ω Resistance
23	RTD Pt-100 Type
24	RTD Ni-100 Type
25	RTD Pt-1000 Type
26	RTD Ni-1000 Type

Register 40012 (Channel Enable) Bit Definition				
Bit 4-15	Bit 3	Bit 2	Bit 1	Bit 0
Unused	Input 3	Input 2	Input 1	Input 0
0 = Disable Input				
1 = Enable Input				

5. Input/Output DATA

SmartMod Analog I/O utilizes both Modbus Registers (40001-40030) and Coils (1-11). It is possible to access all data using Registers only, because the Coils can be accessed through Register 40010.

The following tables lists all Modbus I/O data available.

I/O Register Data (Registers 40014-40022)					
Modbus Register	Description	Access	Minimum	Maximum	Units
40010	Mirror of Coil Data	Read/Write	n/a	n/a	n/a
40014	Cold Junction Temperature	Read-only	-1000	6000	0.01°C
40015	Input 0	Read-only	Depends on Input Type	Depends on Input Type	0.1°C or 0.1 Ω
40016	Input 1	Read-only			
40017	Input 2	Read-only			
40018	Input 3	Read-only			
40019	Reserved	Read-only			
40020	Reserved	Read-only			
40021	Reserved	Read-only			
40022	Reserved	Read-only			

Modbus Coil	Description	Access	Watchdog Event & Power-up Event Operation
00001	Open Detect Input 0	Read-only	If Coil 9 (Watchdog Enabled) is set, Coil 10 (Watchdog Event) will set if the Watchdog Timeout value is exceeded.
00002	Open Detect Input 1	Read-only	
00003	Open Detect Input 2	Read-only	
00004	Open Detect Input 3	Read-only	
00005	Open Detect Input 4	Read-only	
00006	Open Detect Input 5	Read-only	
00007	Open Detect Input 6	Read-only	
00008	Open Detect Input 7	Read-only	The Watchdog Timeout value is set in Register 40009. When set, Coil 10 can be reset by the controller when normal communications resumes.
00009	Watchdog Enabled	Read/Write	
00010	Watchdog Event	Read/Write	
00011	Power-up Event	Read/Write	

RTD Sensor Temperature Ranges		
RTD Sensor Type	Minimum Temperature	Maximum Temperature
Pt-100	-200 degrees C	+850°C
Ni-100	-60 degrees C	+180°C
Pt-1000	-200 degrees C	+200°C
Ni-1000	-60 degrees C	+150°C

6. Implemented Modbus Functions

Function	Code
01	Read multiple coils (0xxxx bank)
02	Read multiple coils (1xxxx bank)
03	Read multiple registers (4xxxx bank)
04	Read multiple registers (3xxxx bank)
05	Write single coil
06	Write single register
15	Write multiple coils
16	Write multiple registers
08	Diagnostic

For RTD100 SmartMod modules, bank 0xxxx is a mirror of bank 1xxxx, as 3xxxx is a mirror of 4xxxx i.e. the first register can be read independently as 30001 (with the function 04) or 40001 (with the function 03)

7. Watchdog

The module has been provided with a Host Watchdog timer which, when it is enabled, issues an alarm event each time the communication between the module and the host is inactive for a period time greater than the programmed one (40009). When the alarm is activated, the values of the outputs are automatically converted to the values set as 'safety value', that corresponding to the state in which the outputs must be placed, and therefore the actuators are putted, to avoid damages to the system in case of failure. Moreover, under the alarm condition the green LED on the front of the module blinks and the "Watchdog Event" coil is forced to a value of 1.

To return from the alarm condition, reset the coil "Watchdog Event" coil: the LED stop blinking and it is possible to set the outputs once again
 There is also a Module Watchdog timer that monitor the internal CPU work and is active when the CPU doesn't function correctly for any reason, and resets the module. After the reset, all outputs will assume their initial default value ("power up value"). This may be different to the output value after the reset.

Register 40009 Definition		
The Watchdog Timeout value is set in Modbus register 40009 (Resolution of 0.5s)		
Coil 00009	Coil 00010	Coil 00011
Watchdog Enabled	Watchdog Event	Power-up Event
0 = Input Disabled		
1 = Input Enabled		
If Coil 9 (Watchdog Enabled) is set, Coil 10 (Watchdog Event) will set if the Watchdog Timeout value is exceeded.		
When set, Coil 10 can be reset by the controller when normal communications resumes.		
The Power-up Event (Coil 11) is set every time the power is applied. It can be cleared by the controller if desired.		

7. Sync

Register	Function
40023	SYNC INPUT VALUE # 0
40024	SYNC INPUT VALUE # 1
40025	SYNC INPUT VALUE # 2
40026	SYNC INPUT VALUE # 3

The Sync function is performed by a command sent to all devices connected on the network. When the devices receive the Sync command, all Input states are saved in the relative register. Doing this, it is possible to read the value of all inputs at the Sync command time.

To send the Sync command, write the value 10 in the "Test" register (40001) and send to node ID 255

NOTE: The sync values are not saved in EPROM.

When the device receives the Sync command, the actual input values in the 40015-40018 registers are saved in registers 40023-40026, channel by channel, as outlined above. These values will be stored until the next sync command, to be read at a following time.

8. LED Indicator

LED	COLOR	STATE	DESCRIPTION
POWER	Green	ON	Device Powered
		OFF	Device Not Powered / Incorrect RS485 Cabling
		Fast Blink	Communication in progress/ (blink frequency depends on baud rate)
		1 Second Blink	Watch-dog Alarm Condition (See Section 6 above)

The LED is located on the front of the model.

9. Calibration

The calibration procedure is performed in factory, on all the modules during the testing phase. However it can be convenient to make another calibration of the module according to the requirements of the user. To do a calibration, it is necessary to use precision instruments and to correctly perform all the steps below. Any error made in the calibration procedure reduces the accuracy and the good operation of the device.

NOTE: For the RTDs, the device uses the calibration of 0-500 Ω or 0-2000 Ω input type.

To re-calibrate the device, follow this procedure:

- 1 – Turn on the device in INIT condition
- 2 – Connect a calibrator to the channel #0.
- 3 – Program the input type to be calibrated
- 4 – Set the calibrator at 0 Ω.
- 5 – Write on the "Test" register (40001) the value 20.
- 6 – Set the calibrator to the full-scale value (500 Ω or 2000 Ω)
- 7 – Write on the "Test" register (40001) the value 30.
- 8 – Repeat point 3 to 7 for each input type to be calibrated.

10. Installation / safety

Warning: Remove power from the OCS controller, CAN port, and any peripheral equipment connected to this local system before adding or replacing this or any module.

- All applicable codes and standards should be followed in the installation of this product.
- Shielded, twisted-pair wiring should be used for best performance.
- Shields may be terminated at the module terminal strip.
- In severe applications, shields should be tied directly to the ground block within the panel.
- Use the following wire type or equivalent: Belden 8441.

For detailed installation and a handy checklist that covers panel box layout requirements and minimum clearances, refer to the hardware manual of the controller you are using.

When found on the product, the following symbols specify:



For UL installation, the device must be powered using a power supply unit classified NEC class 2 SELV.

WARNING – EXPLOSION HAZARD – Do not disconnect equipment unless power has been switched off.
AVERTISSEMENT - RISQUE D'EXPLOSION - AVANT DE DECONNECTER L'EQUIPMENT, COUPER LE COURANT.

WARNING: To avoid the risk of electric shock or burns, always connect the safety (or earth) ground before making any other connections.

WARNING: To reduce the risk of fire, electrical shock, or physical injury it is strongly recommended to fuse the voltage measurement inputs. Be sure to locate fuses as close to the source as possible.

WARNING: Replace fuse with the same type and rating to provide protection against risk of fire and shock hazards.

WARNING: In the event of repeated failure, do not replace the fuse again as a repeated failure indicates a defective condition that will not clear by replacing the fuse.

WARNING: Only qualified electrical personnel familiar with the construction and operation of this equipment and the hazards involved should install, adjust, operate, or service this equipment. Read and understand this manual and other applicable manuals in their entirety before proceeding. Failure to observe this precaution could result in severe bodily injury or loss of life.

11. Technical support

Technical Support at the following locations:

North America:	Europe:
Tel: 317 916-4274	Tel: +353-21-4321266
Fax: 317 639-4279	Fax: +353-21-4321826
Web: http://www.hornerautomation.com	Web: http://www.horner-apg.com
Email: techsppt@heapg.com	Email: tech.support@horner-apg.com

No part of this publication may be reproduced without the prior agreement and written permission of Horner APG, Inc. Information in this document is subject to change without notice.