

# OCS-I/O HE959DIM620 DATASHEET

## 8 Digital 120VAC Inputs

### 1 TECHNICAL SPECIFICATIONS

#### 1.1 General Specifications

Required Power (Steady State)	80mA @ 5V
Digital Inputs (non-isolated)	8
Relative Humidity	5-95% non-condensing
Port Connectors	Phoenix Contact 2201780
Operating Air Temperature	-40°C (-40°F) to 60°C (140°F)
Storage Temperature	-40°C (-40°F) to 85°C (185°F)
Weight	2.84 oz.
Dimensions	76.5mm x 124.5mm x 19mm 3" x 4.9" x 0.75"
Certifications (UL/CE)	North America: <a href="https://hornerautomation.com/certifications/">https://hornerautomation.com/certifications/</a> Europe: <a href="https://www.hornerautomation.eu/support/certifications-2/">https://www.hornerautomation.eu/support/certifications-2/</a>



#### 1.2 Digital Inputs

Inputs per Module	8
Commons per Module	8
Input Voltage Range	90 - 132VAC
Absolute Maximum Voltage	144VAC
Input Impedance	~61.8k
OFF to ON Response	<20ms
ON to OFF Response	<20ms
Galvanic Isolation	No
I/O Indication	Status LED per Input
Connector Tye	Phoenix Contact 2201780

**Cscape Configuration:**  
See MAN1175 for the HE959CNX116.

## 2 WIRING

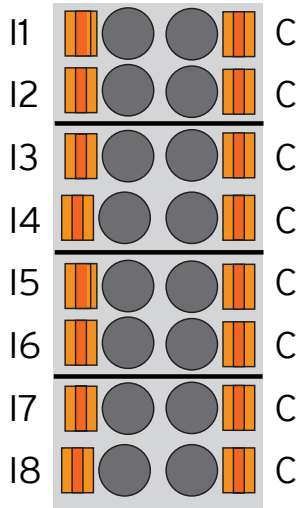

Wiring used for main wiring should be 300V 105°C rating or higher.



All Inputs must be connected to the same voltage level, e.g., connect all to the same 120 VAC source.

8 DIGITAL INPUTS			
Signal	Description	Signal	Description
I1	AC Digital Input 1	C	AC Common
I2	AC Digital Input 2	C	AC Common
I3	AC Digital Input 3	C	AC Common
I4	AC Digital Input 4	C	AC Common
I5	AC Digital Input 5	C	AC Common
I6	AC Digital Input 6	C	AC Common
I7	AC Digital Input 7	C	AC Common
I8	AC Digital Input 8	C	AC Common

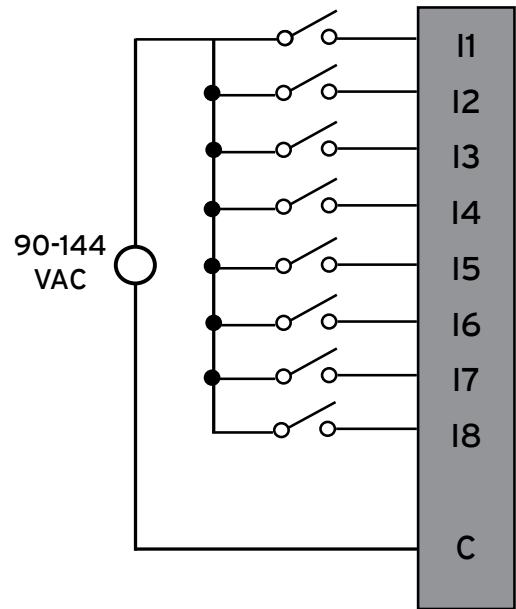

## 3 DIAGNOSTIC LED INDICATORS

Status	OK LED
OFF	Power Up
ON	IO Module Running Normally
BLINK (1Hz)	One of the following errors: a. Communication between IO Base and IO Module (IO ERROR) b. No Configuration c. OCS idle mode

## 4 SAFETY

### 4.1 - WARNINGS



WARNING - If the equipment is used in a manner not specified by Horner APG, the protection provided by the equipment may be impaired.

WARNING - EXPLOSION HAZARD - Do not disconnect equipment unless power has been removed or the area is known to be non-hazardous

AVERTISSEMENT - RISQUE D'EXPLOSION -Ne débranchez pas l'équipement tant que l'alimentation n'a pas été coupée ou que la zone n'est pas dangereuse.

WARNING - EXPLOSION HAZARD - Substitution of any component may impair suitability for Class I, Division 2  
AVERTISSEMENT - RISQUE D'EXPLOSION -Le remplacement de tout composant peut nuire à la compatibilité avec la classe I, division 2

WARNING - POSSIBLE EQUIPMENT DAMAGE - Remove power from the I/O Base and any peripheral equipment connected to this local system before adding or replacing this or any module.  
AVERTISSEMENT - DOMMAGES POSSIBLES À L'ÉQUIPEMENT - Coupez l'alimentation de la base d'E / S et de tout équipement périphérique connecté à ce système local avant d'ajouter ou de remplacer ce module ou tout autre module.



### 4.2 - SAFETY

- All applicable codes and standards should be followed in the installation of this product.
- Shielded, twisted-pair wiring should be used for best performance.
- Shields should be grounded at one end only, preferably at the end providing the best noise shunting.
- Use the following wire type or equivalent: Belden 8441.

## 5 INSTALLATION

The HE959DIM620 is compact and mounts on a DIN-rail. Each I/O module installed adds width in increments of 19mm.

**NOTE:** The distance between wiring duct and surrounding modules should be at least 50mm apart.

- OCS-I/O modules can be added after the OCS-I/O base has been installed on the DIN-rail.
- The OCS-I/O modules can be hot-swapped when powered. However, I/O scanning will stop until the correct modules for the system are detected in all slots.

Use the following steps to physically add the I/O modules:

- Couple the bus connectors together to form a backplane that can accept up to 8 modules, including the CNX116 or another base.
- Snap the bus connectors into the DIN rail. The DIN rail should be 35 mm x 7.5 mm and made to EN 60715 standards.
- Place the OCS-I/O base to the leftmost connector.
- Insert the modules by latching at the top of the DIN rail first, and then rocking down until the latch at the bottom of the DIN rail engages.
- To remove a module, insert a flat blade screwdriver into the metal DIN rail latch at the bottom of the module. Pry down to release the latch, then rock the module up and off the DIN rail. Modules may be removed while powered; however, I/O scanning on the remaining modules will stop and the I/O will enter the default state until a new module is inserted and all modules in the configuration are present.

## 6 PART NUMBER

**HE959DIM620**

## 7 TECHNICAL SUPPORT

For assistance and manual updates, contact Technical Support at the following locations:

### North America

(317) 916-4274

[www.hornerautomation.com](http://www.hornerautomation.com)

APGUSATechSupport@heapg.com

### Europe

(+) 353-21-4321-266

[www.hornerautomation.eu](http://www.hornerautomation.eu)

technical.support@horner-apg.com