

HMI Connect Displays Datasheet

MAN1517_04_EN_HMIC_DS

The HMI Connect displays provide users of the CPU units that have an HMI Connect port, and who prefer an HMI interface, with four flexible, easy-to-use, and high-quality options.

The 4", 7", 10", and 15" displays each connect to the CPU using an HMI Connect port using a single cable up to 8 meters long, allowing for more versatility in panel creation without quality degradation.

Power and communication are provided by the single cable.

Size	4-inch	7-inch	10-inch	* 15-inch
Part Number	HE-959HMI-04	HE-959HMI-07	HE-959HMI-10	HE-959HMI-15

HMI Connect Cable	1 Meter	3 Meter	8 Meter
Part Number	HE-HMICBL-1M	HE-HMICBL-3M	HE-HMICBL-8M

	4"	7"	10"	* 15"
Resolution	480 x 272	800 x 480	1024 x 600	1024 x 768
Brightness	450 cd/m ²	420 cd/m ²	300 cd/m ²	500 cd/m ²
Mounting	Panel 4.705" x 3.563" 119.5 x 90.5mm	Panel or VESA 6.890" x 5.193" 175 x 131.9mm		
		Four (4) Hole Attachment Interface: Hole Pattern: 100 x 100 mm		
		Four (4) Hole Attachment Interface: Screw Size: M5-0.8 x 7mm		
Touchscreen	Resistive			
Protection Grade	IP 65 / NEMA 4X (from front)			
Video Input	FPD Link			
Power	10-30 volts provided by controller			19-30 VDC
mA@24V	59 mA	91 mA	129 mA	362 mA
W@24V	1.4 Watts	2.2 Watts	3.1 Watts	8.7 Watts
Operating Temperature	-10°C – +60°C			
Width, Height, Depth	96.2 x 125.2 x 35.9 mm	143.56 x 186.07 x 49.51 mm	167.81 x 265.25 x 56.46 mm	281.28 x 364.28 x 63.21 mm
Weight	215.6 g (7.6 oz)	548.1 g (19.3 oz)	1117 g (39.4 oz)	2704 g (95.4 oz)

* To connect the chassis ground, the perimeter mounting studs must be installed with a wire jumper to earth ground added.

For additional information, see [Documentation Search](#) on the Horner Website

DIMENSIONS

ALERT: NOT TO SCALE

(The following templates are not to scale)

HE-959HMI-04

2D Mechanical Diagram

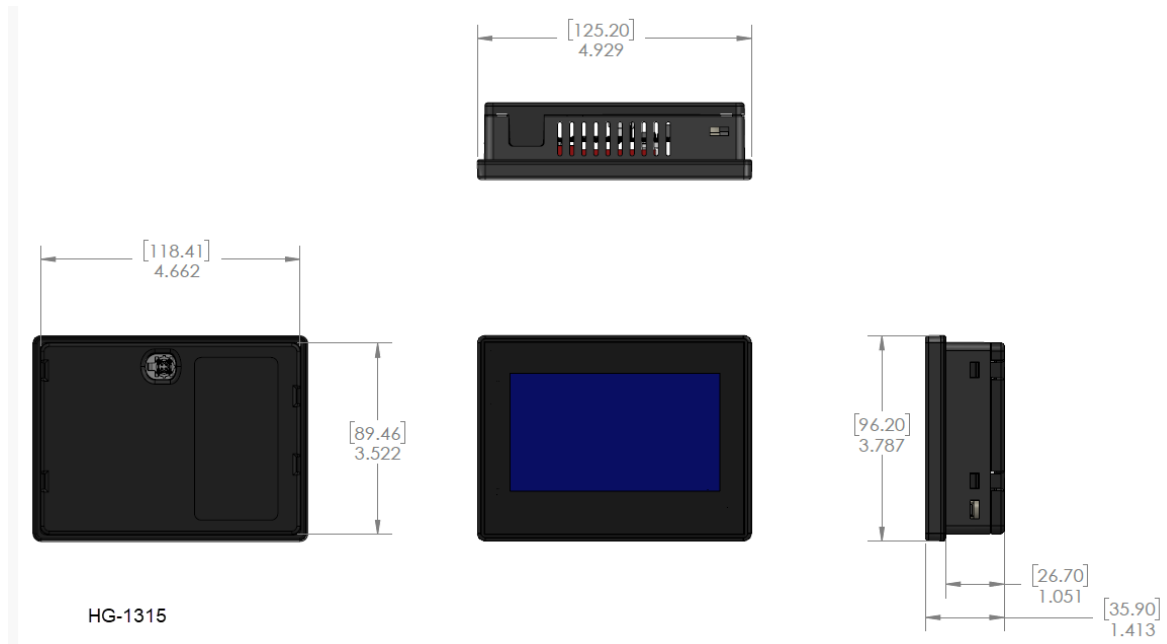

Cutout Diagram

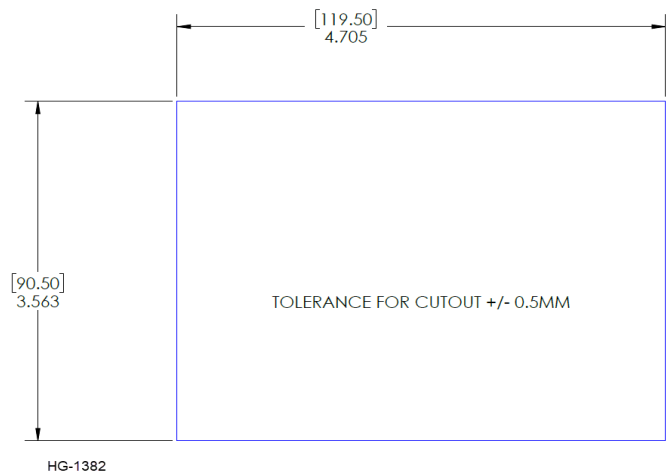

HE-959HMI-07

2D Mechanical Diagram

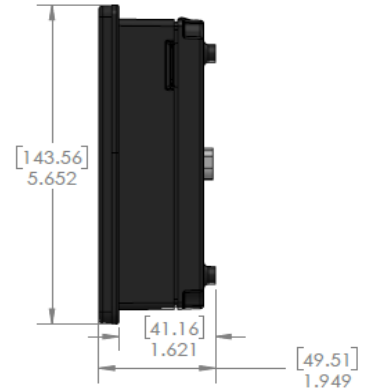
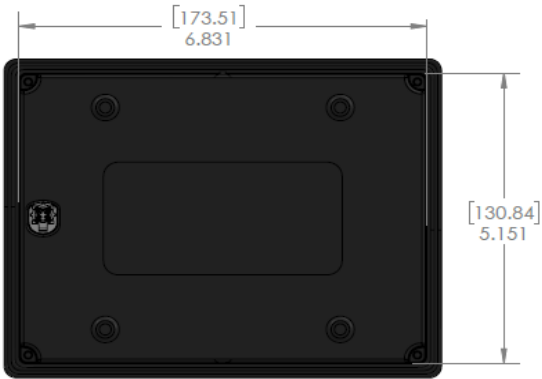
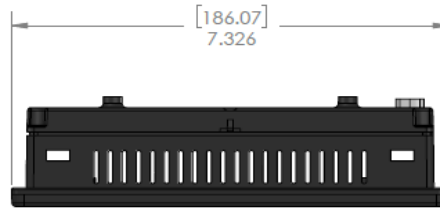

HG-1316

Cutout Diagram

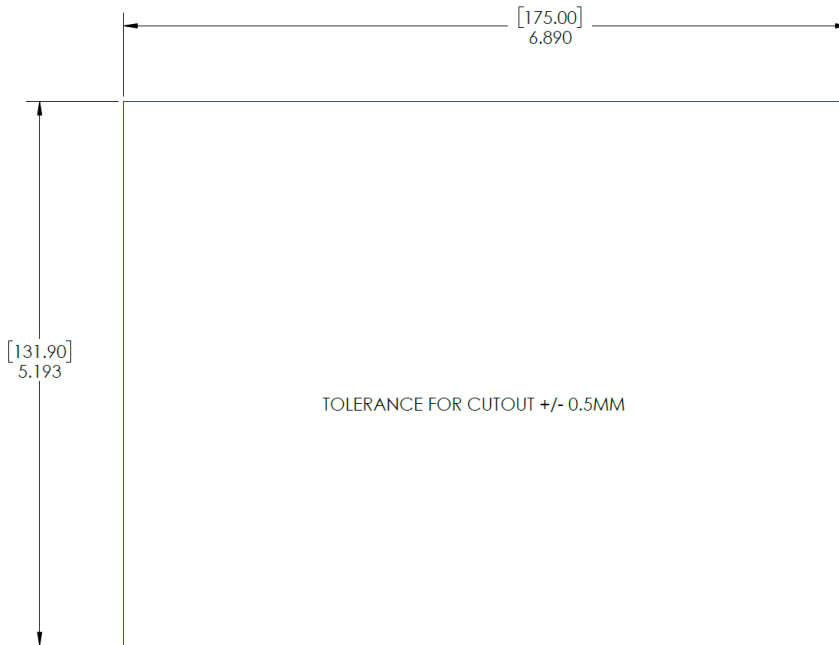

NOTE: VESA MOUNT 100X100
THREAD USED: M5 X 0.8

HG-1383

HE-959HMI-10

2D Mechanical Diagram

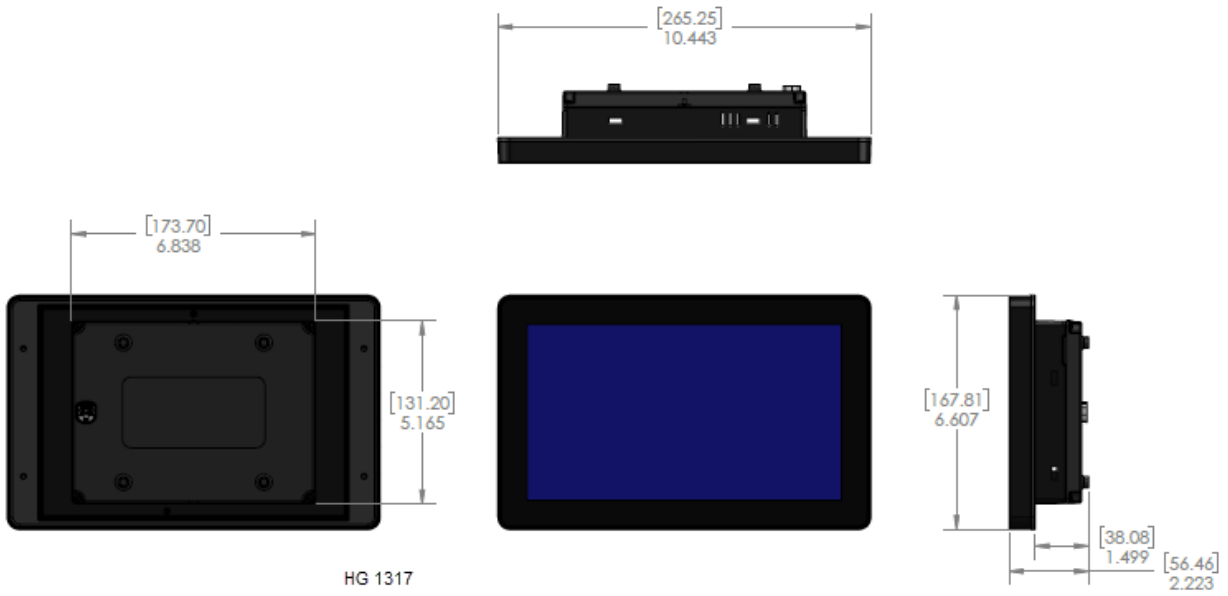

Cutout Diagram

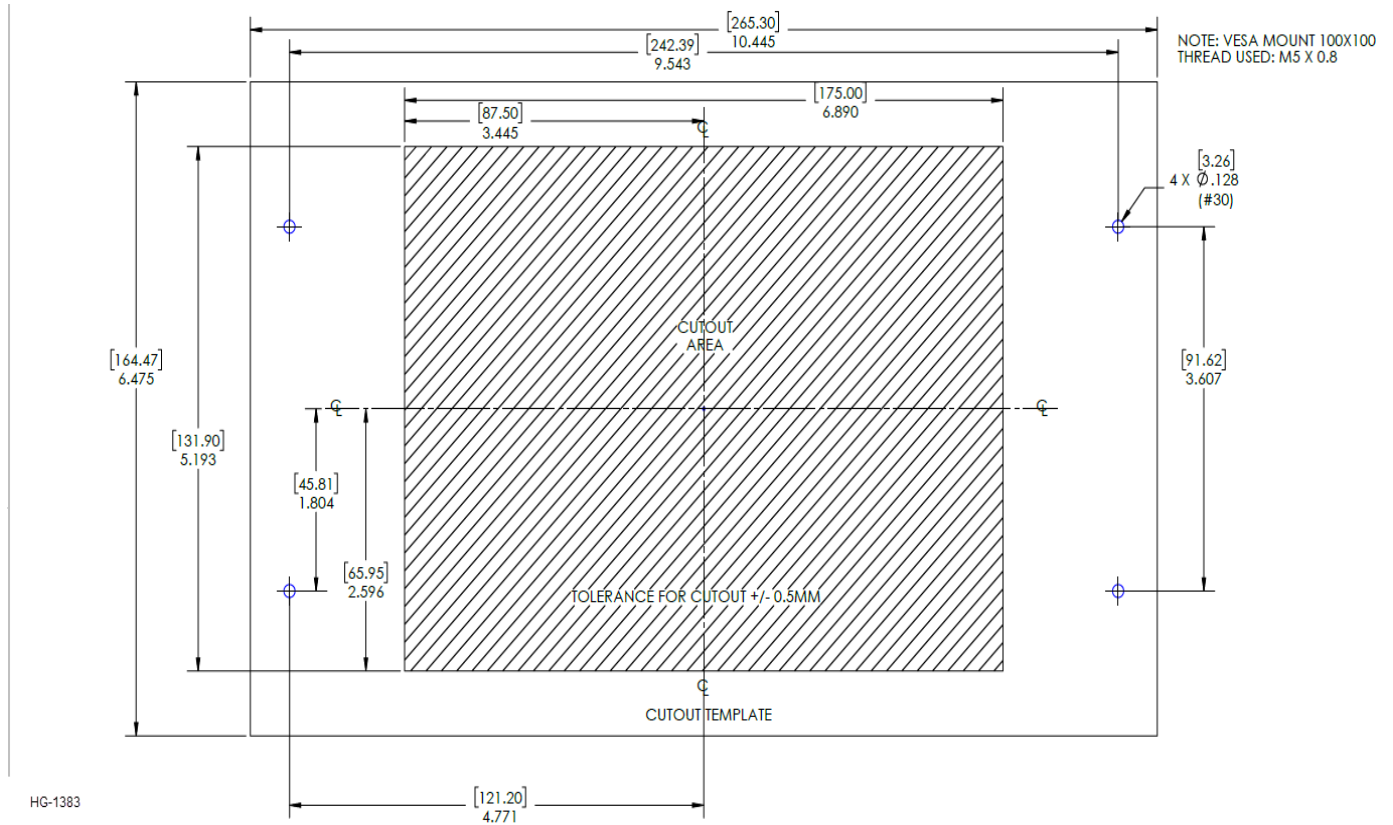

HE-959HMI-15

Important: To connect the chassis ground, the perimeter mounting studs must be installed with a wire jumper to earth ground added.

2D Mechanical Diagram

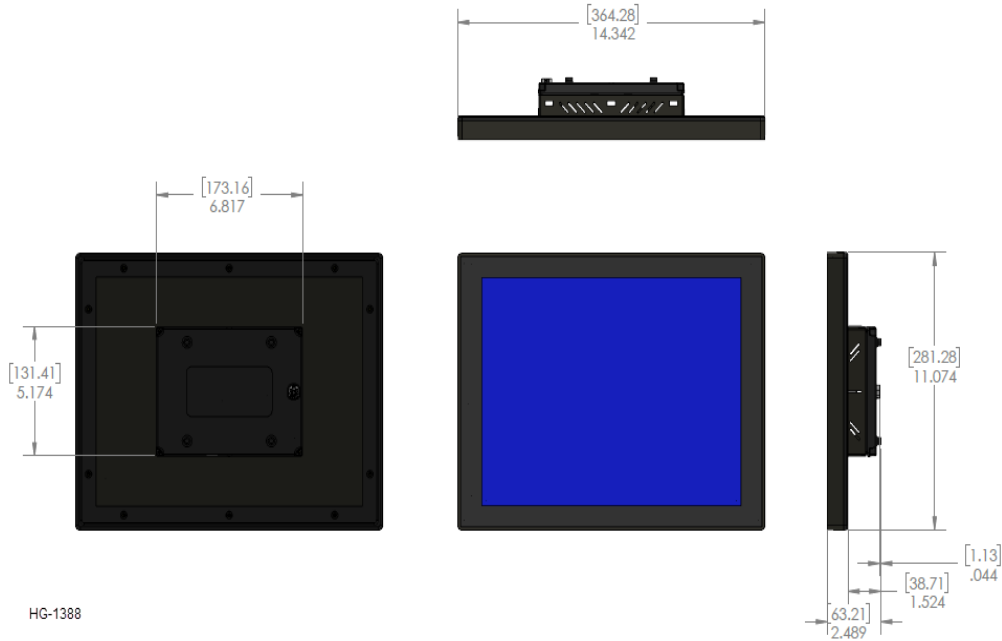

Cutout Diagram

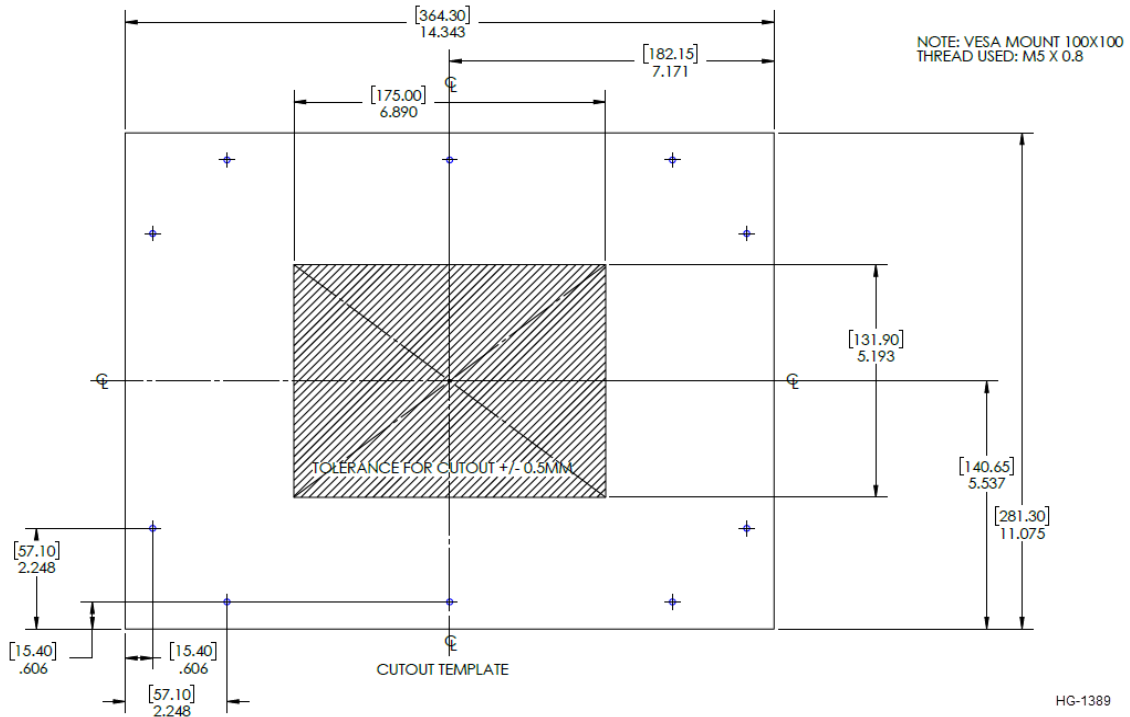

INSTALLATION

Insert one cable end into the display port of the HMI Connect display, and the other cable end into the CPU with an HMI Connect port.



Close-up of CPU300 Display Port



Warning: Disconnect with Care

HMI Connect displays use an automotive connector that is robust and rugged. It was not designed to be plugged and unplugged repeatedly. Cables used for development or plugged and unplugged approximately 10 times should be replaced in a production environment.

1. Hold the connector firmly by hand only.
2. Press in the retention clip with a small, flat blade screwdriver.
3. Pull the connector backwards out of the port.
Do not bend as doing so could break the cable.

SAFETY & MAINTENANCE

Warnings

1. To avoid the risk of electric shock or burns, always connect the safety (or earth) ground before making any other connections.
2. To reduce the risk of fire, electrical shock, or physical injury, it is strongly recommended to fuse the voltage measurement inputs. Be sure to locate fuses as close to the source as possible.
3. Replace fuse with the same type and rating to provide protection against risk of fire and shock hazards.
4. In the event of repeated failure, do **NOT** replace the fuse again as repeated failure indicates a defective condition that will **NOT** clear by replacing the fuse.
5. Only qualified electrical personnel familiar with the construction and operation of this equipment and the hazards involved should install, adjust, operate, or service this equipment.
6. Read and understand this manual and other applicable manuals in their entirety before proceeding. Failure to observe this precaution could result in severe bodily injury or loss of life.
7. **WARNING:** Battery may explode if mistreated. Do not recharge, disassemble, or dispose of in fire.
8. **WARNING:** EXPLOSION HAZARD - Batteries must only be changed in an area known to be non-hazardous.
9. **WARNING:** Do not disconnect while circuit is live unless area is known to be non-hazardous.

FCC Compliance

This device complies with Part 15 of the FCC Rules. Operation is subject to the following two conditions:

1. This device may not cause harmful interference.
2. This device must accept any interference received, including interference that may cause undesired operation.

Precautions

All applicable codes and standards need to be followed in the installation of this product. Adhere to the following safety precautions whenever any type of connection is made to the module:

1. Connect the safety (earth) ground on the power connector first before making any other connections.
2. When connecting to the electric circuits or pulse-initiating equipment, open their related breakers.
3. Do NOT make connection to live power lines.
4. Make connections to the module first; then connect to the circuit to be monitored.
5. Route power wires in a safe manner in accordance with good practice and local codes.
6. Wear proper personal protective equipment including safety glasses and insulated gloves when making connections to power circuits.
7. Ensure hands, shoes, and floor are dry before making any connection to a power line.
8. Make sure the unit is turned OFF before making connections to terminals.
9. Make sure all circuits are de-energized before making connections.
10. Before each use, inspect all cables for breaks or cracks in the insulation. Replace immediately if defective.
11. Use copper conductors in field wiring only, 60/75°C.
12. Use caution when connecting controllers to PCs via serial or USB. PCs, especially laptops, may use “floating power supplies” that are ungrounded. This could cause a damaging voltage potential between the laptop and controller. Ensure the controller and laptop are grounded for maximum protection. Consider using a USB isolator due to voltage potential differences as a preventative measure.



Technical Support

North America	Europe
1 (317) 916-4274 1 (877) 665-5666 www.hornerautomation.com APGUSATechSupport@heapg.com	+353 (21) 4321-266 www.hornerautomation.eu technical.support@horner-apg.com