

# XL7 Prime Datasheet - Model 4

24 DC In, 16 DC Out, 2 – 12-bit Analog In

MAN1343\_23\_EN\_XL7P\_Mod4



## Part Numbers

Global Part Number	HE-XPW1E4
European Part Number	HEXP391C114

## User Manual and Add-Ons

Find the documents via the [Documentation Search](#).

Part #	Description
MAN0974	XL7 & XL7 Prime User Manual
HE-PRGA2C	Type A USB to Type C USB Programming Cable
HE-PRGC2C	Type C USB to Type C USB Programming Cable
HE-XDAC	2 channel Analog Output I/O option kit, selectable 0-10V, +/-10V, 4-20mA.
HE-XDAC107	4 channel Analog Output I/O option kit, selectable 0-10V, +/-10V, 4-20mA.
HE-XKIT	Blank I/O Board
HE200MJ2TRM	Adapter, RJ45 (8P8C) male to 8-position terminal strip.
HE-FBD001	Ferrite core for filtering out electrical noise.

## Battery Maintenance

The XL7 Prime uses a Renata CR2032 lithium battery to run the Real Time Clock. The battery life is 7-10 years.

## Table of Contents

User Manual and Add-Ons .....	1
Battery Maintenance .....	1
<b>TECHNICAL SPECIFICATIONS .....</b>	<b>2</b>
General Specifications .....	2
Control and Logic .....	2
User Interface .....	3
Connectivity .....	3
<b>CONTROLLER OVERVIEW .....</b>	<b>4</b>
Power Wiring .....	5
<b>MODEL 4 SPECIFICATIONS .....</b>	<b>6</b>
Digital DC Input .....	6
Digital DC Outputs .....	6
Analog Inputs .....	7
<b>WIRING: INPUTS AND OUTPUTS .....</b>	<b>8</b>
Analog Inputs Information .....	8
Digital Inputs Information .....	8
Positive Logic vs. Negative Logic .....	8
Screw Torque for Reattaching Back Cover After I/O	
Jumper Update .....	9
J1 (Orange) Wiring - Digital In/Analog In .....	10
J2 (Black) Wiring - Digital Out .....	11
J3 (Orange) Wiring - Digital In/Positive Logic .....	12
J4 (Orange) Wiring - Digital Out/Positive Logic .....	12
Wiring Details .....	12
Built-In I/O .....	13
Analog Input Transient-Voltage-Suppression Diode	
Failure .....	13
<b>COMMUNICATIONS .....</b>	<b>14</b>
Serial Communication .....	14
Ethernet .....	14
DIP Switches .....	15
CAN Communications .....	15
<b>DIMENSIONS &amp; INSTALLATION .....</b>	<b>16</b>
Model 4 .....	19
Installation Information .....	22
Installation Procedure .....	22
<b>SAFETY &amp; MAINTENANCE .....</b>	<b>23</b>
Warnings .....	23
FCC Compliance .....	23
Precautions .....	23



## TECHNICAL SPECIFICATIONS

### General Specifications

Typical Power Backlight 100%	653mA @ 10VDC (6.53W) 352mA @ 24VDC (8.44W)
Backlight 50%	557mA @ 10VDC (5.57W) 308mA @ 24VDC (7.38W)
Backlight Off	475mA @ 10VDC (4.75W) 2.69mA @ 24VDC (6.45W)
Required Power (Inrush)	25A for < 1ms @ 24VDC, DC switched
Heater Option*	Add 250mA for Heater (24VDC)
Primary Power Range	10 - 30VDC
Maximum Current	1100mA, Class 2
Relative Humidity	5 to 95%, Non-Condensing
Clock Accuracy	± 20 ppm maximum at 25°C (± 1 min/month)
Real Time Clock	Battery Backed, Lithium Coin
Operating Temperature	-10°C to +60°C
Storage Temperature	-20°C to +60°C
Weight	28.70 oz (813.5g)
Altitude	Up to 2000m
Pollution Degree	Degree 2 Rating
Certifications (UL/CE)	<a href="#">North America</a> or <a href="#">Europe</a>
Enclosure Type	1, 3R, 4, 4X, 12, 12K & 13

### Control and Logic

Control Language Support	Register-Based Advanced Ladder Logic; Variable-Based Advanced Ladder; IEC 61131-3 Languages
Logic Program Size	2MB, maximum
Scan Rate	0.02ms/kB
Digital Inputs	2048
Digital Outputs	2048
Analog Inputs	512
Analog Outputs	512
General Purpose Registers	50,000 (words) Retentive 16,384 (bits) Retentive 16,384 (bits) Non-retentive

#### USB Webcams

USB Webcams supported should support the UVC (USB Video class) protocol for the OCS to be able to display video. Most USB based video devices support this today. Special features such as zoom and high definition are not supported by the OCS.

## User Interface

Display Type	7" TFT Color
Resolution	QVGA (800 x 480)
Color	16-bit (65,535)
Screen Memory	17MB
User-Programmable Screens	1023 max pages; 1023 objects per page
Backlight	LED - 50,000 hour life
Brightness Control	0-100% via System Register %SR57
Number of Keys	6

## Connectivity

Serial Ports	1 RS-232 & 1 RS-485 on first Modular Jack (MJ1/2); 1 RS-232 or 1 RS-485 on second Modular Jack (MJ3)
USB C	USB 2.0 (480Mbps) Programming & Data Access, Device Power (except backlight)
USB A (500mA max)	USB 2.0 (480Mbps) for USB flash drives (2TB)
CAN Port (Isolated 1kV)	2 x Remote I/O, Peer-to-peer Comms, Cscape
CAN Protocols	CsCAN, CANopen, DeviceNet, J1939
Ethernet	2 x 10/100 Mb (Auto-MDX)
Ethernet Protocols	TCP/IP, Modbus TCP, FTP, SMTP, EGD, ICMP, ASCII, Cscape, EtherNet/IP
Remote I/O	OCS-I/O
Removable Memory	microSD, SDHC, SDXC in FAT32 format, support for 32GB max. Application Updates, Datalogging
Audio	Line Out, Microphone In

### UV and Sunlight Protection

Protection of this product from direct sunlight is recommended but not required. The overlay is made of Lexan HP92W which is designed to be UV resistant. Protection will further extend the life of the overlay and touchscreen

## CONTROLLER OVERVIEW



HG-1315

- |   |  |
|---|--|
| <ol style="list-style-type: none"> <li>1. Touchscreen</li> <li>2. Function Keys</li> <li>3. MJ1: RS232 / MJ2: 1/2 Duplex RS485</li> <li>4. DIP Switches</li> <li>5. MJ3: RS-232/485 Serial Port</li> <li>6. CAN1 Port</li> <li>7. PWR: 10-30VDC In</li> </ol> | <ol style="list-style-type: none"> <li>8. LAN 1&amp;2 Ports</li> <li>9. Audio Out Port</li> <li>10. USB 2.0 "A": Flash Drive</li> <li>11. OCS-I/O Expansion<br/>(This port is reserved for future functionality.)</li> <li>12. CAN2 Port</li> <li>13. Bootloader Mode Switch</li> <li>14. USB C: Programming</li> <li>15. microSD: Data Storage</li> </ol> |
|---|--|

## Power Wiring

**NOTE:** The Primary Power Range is 10VDC to 30VDC.

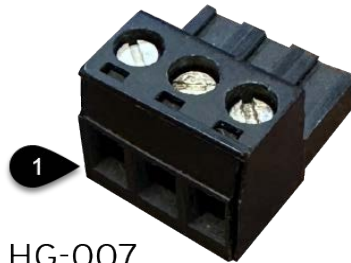

HG-007

Primary Power Port Pins		
PIN	Signal	Description
1	Ground	Frame Ground
2	DC-	Input Power Supply Ground
3	DC+	Input Power Supply Voltage

### DC Input / Frame

- Solid/Stranded Wire: 12-24 AWG (2.5-0.2mm<sup>2</sup>)
- Strip length: 0.28" (7mm)
- Torque, Terminal Hold-Down Screws: 4.5 – 7 in•lbs (0.50 – 0.78 N•m)
- DC- is internally connected to I/O V-, but is isolated from CAN V-. A Class 2 power supply must be used.

### Power Up

1. **OPTION:** Attach ferrite core with a minimum of two turns of the DC+ and DC- signals from the DC supply that is powering the controller.



HG-006

2. Connect to earth ground.
3. Apply recommended power.

## MODEL 4 SPECIFICATIONS

### Digital DC Input

Inputs per Module	24 Including 4 Configurable HSC Inputs	
Commons per Module	1	
Input Voltage Range	12VDC/24VDC	
Absolute Maximum Voltage	30VDC Max.	
Input Impedance	10k $\Omega$	
Input Current	Positive Logic	Negative Logic
Upper Threshold	0.8mA	-1.6mA
Lower Threshold	0.3mA	-2.1mA
Maximum Upper Threshold	8VDC	
Minimum Lower Threshold	3VDC	
OFF to ON Response	1ms	
ON to OFF Response	1ms	
High Speed Counter Maximum Frequency	1MHz (Quadrature Frequency 500kHz)	

### Digital DC Outputs

Outputs per Module	16 Including 2 Configurable PWM Outputs	
Commons per Module	1	
Output Type	Sourcing/10k $\Omega$ Pull-Down	
Output Frequency	10kHz (up to 500kHz when using the HE-XHSQ add-on module)	
Absolute Maximum Voltage	28VDC	
Output Protection	Short Circuit	
Maximum Output Current/Point	0.5A	
Maximum Total Current	4A Continuous	
Maximum Output Supply Voltage	30VDC	
Minimum Output Supply Voltage	10VDC	
Maximum Voltage Drop at Rated Current	0.25VDC	
Maximum Inrush Current	650mA per Channel	
Minimum Load	None	
OFF to ON Response	1ms	
ON to OFF Response	1ms	
Output Characteristics	Current Sourcing (Positive Logic)	
Rise Time	50 - 115 $\mu$ s	
Fall Time	8-20 $\mu$ s	

## Analog Inputs

Number of Channels	2
Input Ranges	0 – 10VDC; 0 – 20mA; 4 – 20mA
Safe Input Range	-0.5V to +12V
Input Impedance (Clamped @ -0.5VDC to 12VDC)	Current Mode: 100Ω Voltage Mode: 500kΩ
Nominal Resolution	12 Bits
%AI full scale	10V, 20mA: 32,000 counts full scale
Maximum Over-Current	35mA
Conversion Speed	All channels converted once per ladder scan
Maximum Error @ 25°C (excluding zero)	4-20mA 1.00% 0-20mA 1.00% 0-10VDC 0.50%
Filtering	160Hz hash (noise) filter 1-128 scan digital running average filter

## WIRING: INPUTS AND OUTPUTS

### Analog Inputs Information

Raw input values for channels 1-4 are found in the registers as Integer-type data with a range from 0 – 32000. Analog inputs may be filtered digitally with the Filter Constant found in the Cscape Hardware Configuration for Analog Inputs. Valid filter values are 0-7 and act according to the following chart:

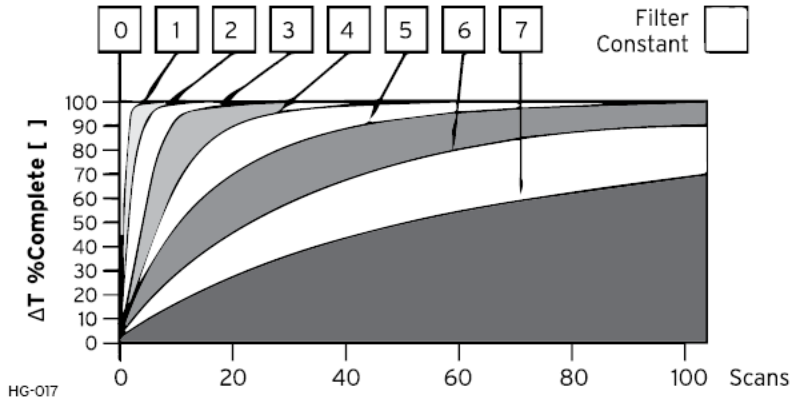

Data Values	
Input Mode:	Data Format, 12-bit INT:
0-20mA, 4-20mA	0-32000
0-10V	0-32000

### Digital Inputs Information

#### Positive Logic vs. Negative Logic

The OCS can be wired for positive logic inputs or negative

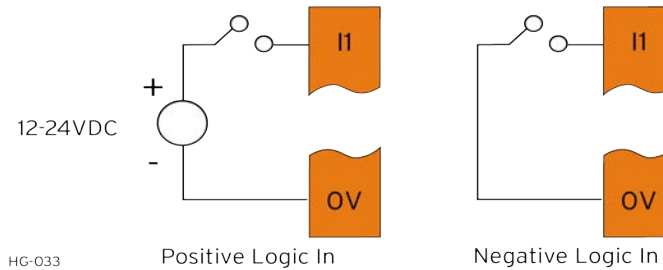

Digital inputs may be wired in either a Positive Logic or Negative Logic fashion as shown. The setting in the Cscape Hardware Configuration for the Digital Inputs must match the wiring used in order for the correct input states to be registered. When used as a normal input and not for high speed functions, the state of the input is reflected in registers %I1 – %I12.

## Jumper Settings for Model 4



Location of I/O jumpers (JP1 & JP3) and wiring connectors (J1, J2, J3 & J4) with back cover removed.

### JP1 Digital DC Inputs

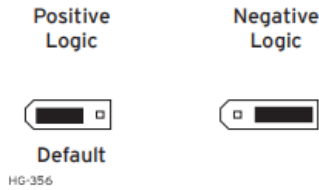

### JP3 Analog In



**NOTE:** The Cscape Module Configuration must match the selected I/O (JP) jumper settings.

**NOTE:** When using JP3 (A1-A2), each channel can be independently configured.

## Screw Torque for Reattaching Back Cover After I/O Jumper Update

XLE/XLT, XL4/XL4 Prime, EXL6/XL6 Prime, Canvas 4	3.0 - 4.0 in•lbs (0.34 - 0.45 N•m)
XL15 Prime, EXLW/ XLW Prime, XL7/XL7 Prime, EXL10/XL10 Prime, XL10W Prime, Canvas 7, Canvas 7D, Canvas 10D	3.0 - 3.5 in•lbs (0.34 - 0.40 N•m)

# J1 (Orange) Wiring - Digital In/Analog In

Pin	Signal Name
I1 (%I1)	Digital In 1
I2 (%I2)	Digital In 2
I3 (%I3)	Digital In 3
I4 (%I4)	Digital In 4
I5 (%I5)	Digital In 5
I6 (%I6)	Digital In 6
I7 (%I7)	Digital In 7
I8 (%I8)	Digital In 8
H1 (%I9)	HSC1/Digital In. 9
H2 (%I10)	HSC1/Digital In. 10
H3 (%I11)	HSC1/Digital In. 11
H4 (%I12)	HSC1/Digital In. 12
A1 (%AI1)	Analog In 1
A2 (%AI2)	Analog In 2
0V	Common

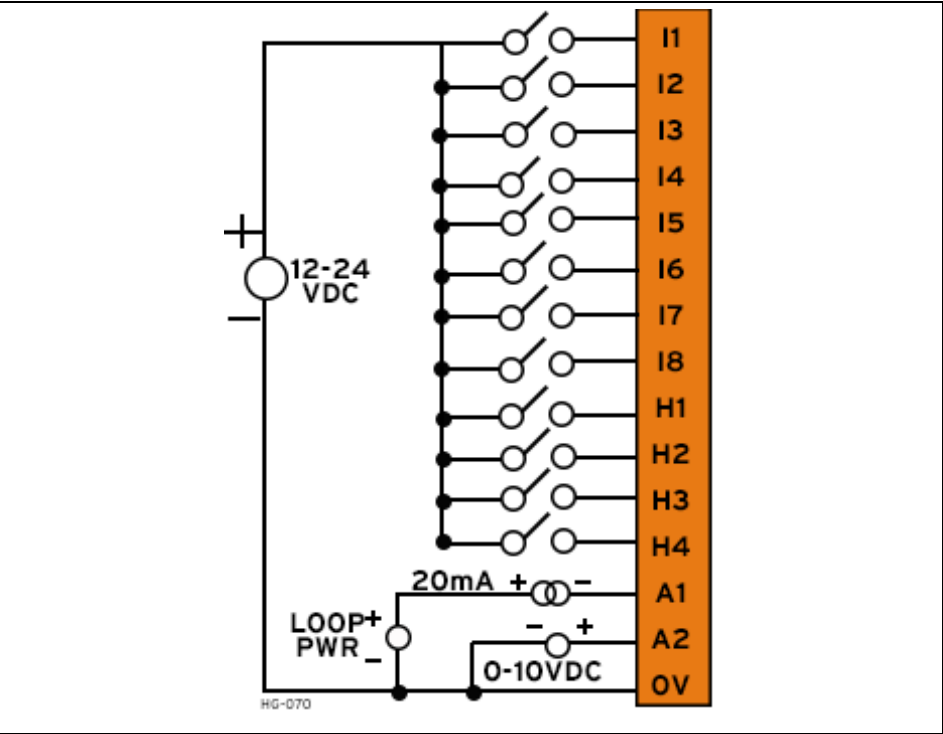

**20mA Analog In - Not Self-Powered**

HG-360

**20mA Analog In - Self-Powered**

HG-223

**0-10VDC IN**

HG-359

### J2 (Black) Wiring - Digital Out

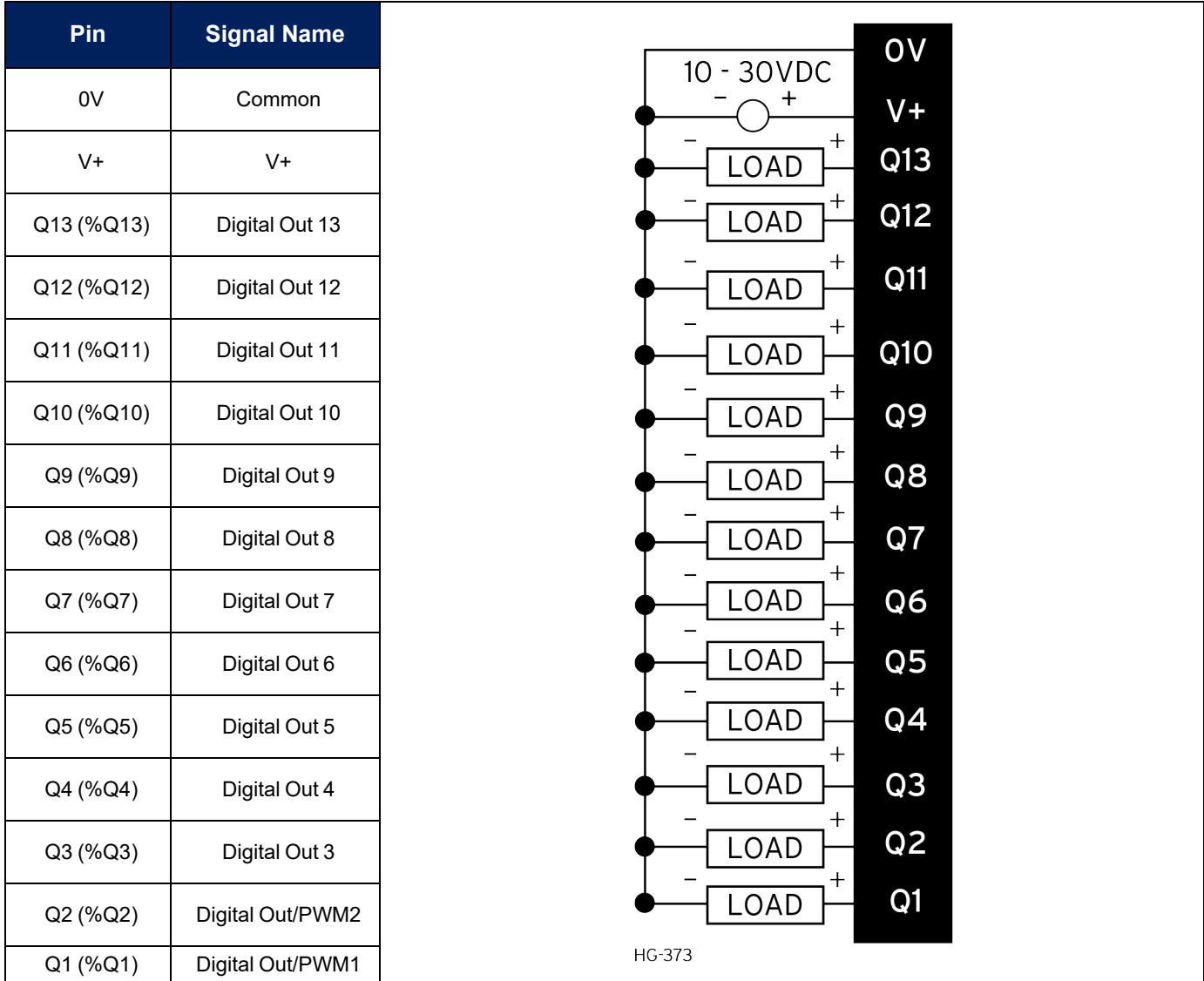

### J3 (Orange) Wiring - Digital In/Positive Logic

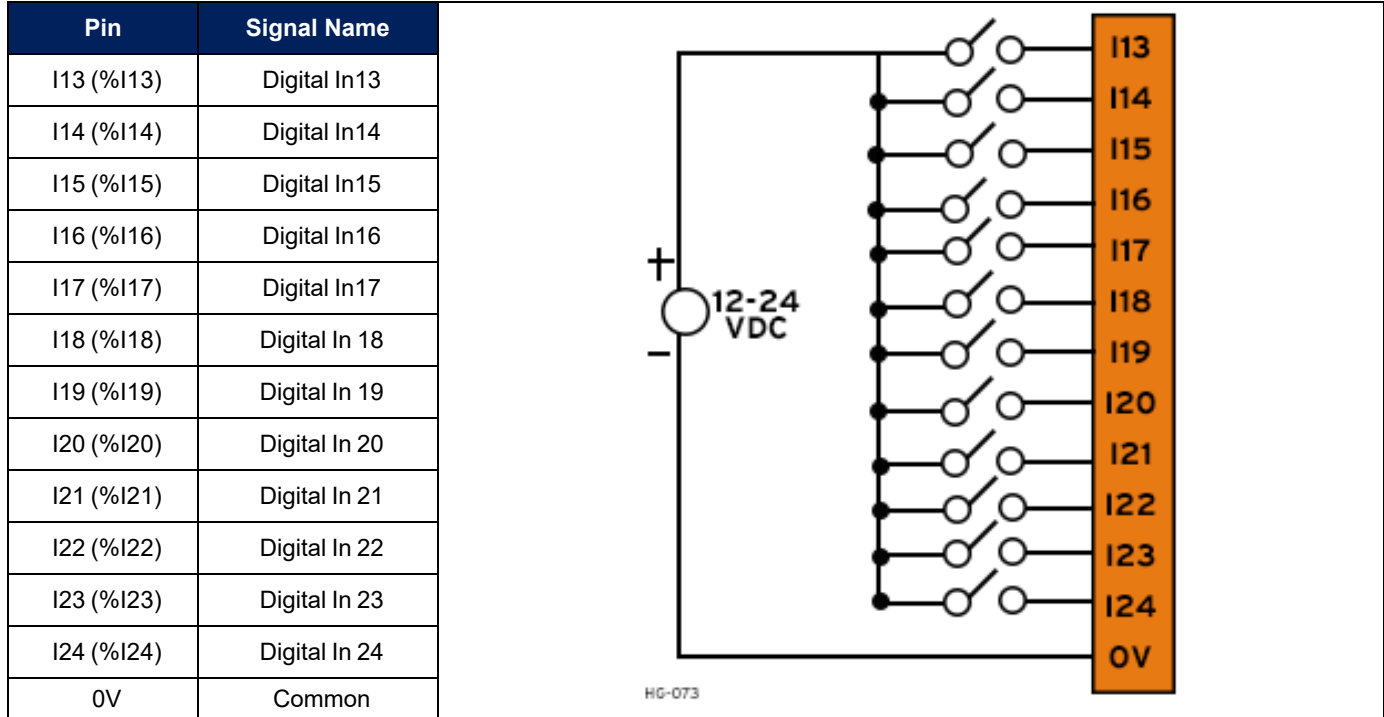

### J4 (Orange) Wiring - Digital Out/Positive Logic

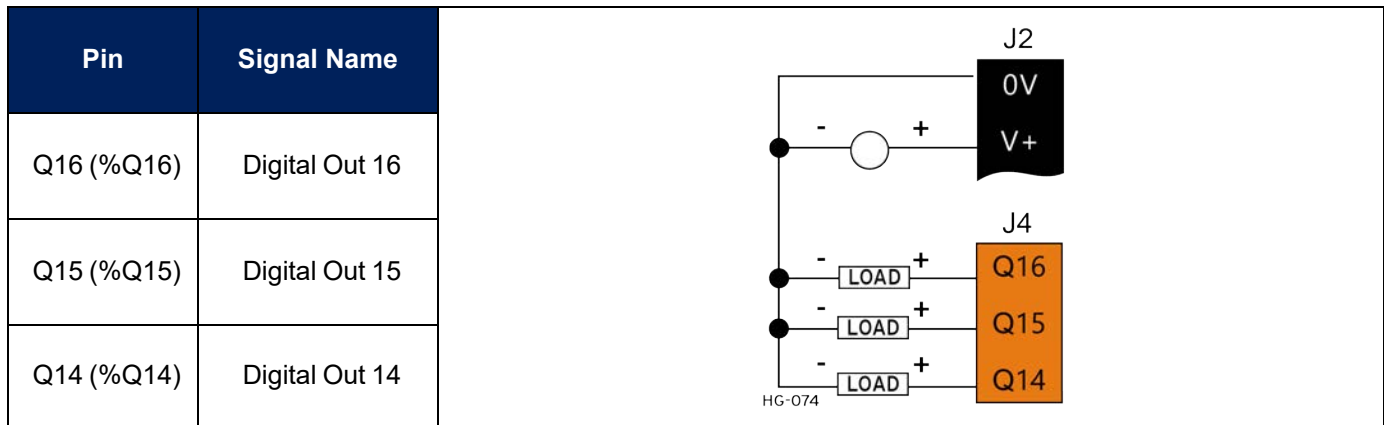

**NOTE:** J2 must also be connected. Strip Length: 0.28" (7mm).

### Wiring Details

**Solid/Stranded Wire:** 12-24 AWG (2.5-0.2mm<sup>2</sup>).

**Strip Length:** 0.28" (7mm).

**Torque, Terminal Hold-Down Screws:** 4.5 – 7 in•lbs (0.50 – 0.78 N•m).

## Built-In I/O

The I/O is mapped into OCS Register space, in three separate areas: Digital/Analog I/O, High-Speed Counter I/O, and High-speed Output I/O. Digital/Analog I/O location is fixed starting at 1, but the high-speed counter and high-speed output references may be mapped to any open register location.

Digital and Analog I/O Functions	
Digital Inputs	%I1-24
Reserved	%I25-31
ESCP Alarm	%I32
Digital Outputs	%Q1-16
Reserved	%Q17-24
Analog Inputs	%AI1-2
Reserved	%AI3-12
Analog Outputs	n/a
Reserved	%AQ1-8

## Analog Input Transient-Voltage-Suppression Diode Failure

A common cause of Analog Input Transient-Voltage-Suppression Diode Failure on Analog Inputs Model 2, 3, 4 & 5: If a 4- 20mA circuit is initially wired with loop power, but without a load, the analog input could see 24VDC. This is higher than the rating of the Transient-Voltage-Suppression Diode. This can be solved by NOT connecting loop power prior to load connection, or by installing a low-cost PTC in series between the load and analog input.

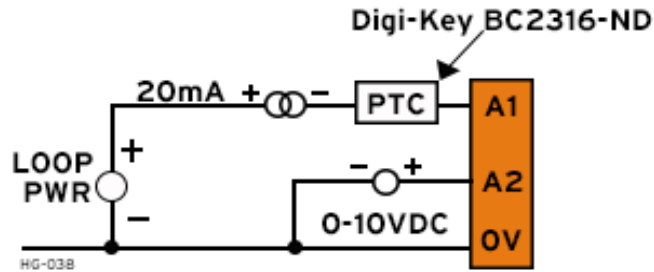

# COMMUNICATIONS

## Serial Communication

### MJ1/2 Serial Ports

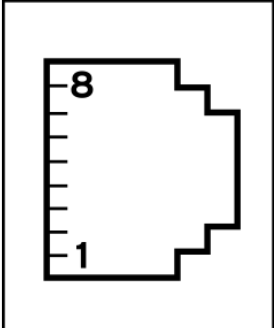
 <p>HG-008</p>	<p><b>MJ1:</b> RS-232 w/Full Handshaking  <b>MJ2:</b> RS-485 Half-Duplex</p>	<b>MJ1 Pins</b>		<b>MJ2 Pins</b>		
		PIN	SIGNAL	DIRECTION	SIGNAL	DIRECTION
		8	TXD	OUT	--	--
		7	RXD	IN	--	--
		6	0V	COMMON	0V	COMMON
		5	+5V @ 60mA	OUT	+5V @ 60mA	OUT
		4	RTS	OUT	--	--
		3	CTS	IN	--	--
		2	--	--	RX-/TX-	IN/OUT
		1	--	--	RX+/TX+	IN/OUT

### MJ3 Serial Port

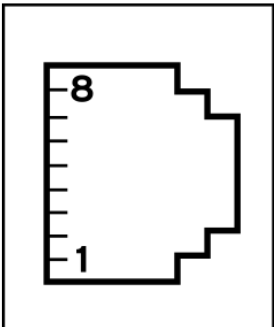
 <p>HG-008</p>	<p>2 Multiplexed Serial Ports on One Modular Jack (8 position)</p>	<b>MJ3 PINS</b>		
		PIN	SIGNAL	DIRECTION
		8	TXD RS-232	OUT
		7	RXD RS-232	IN
		6	0V	COMMON
		5	+5V @ 60mA	OUT
		4	TX- RS-485	OUT
		3	TX+ RS-485	OUT
		2	RX- RS-485	IN
		1	RX+ RS-485	IN

**NOTE:** Attach optional [ferrite core](#) with a minimum of two turns of serial cable.

## Ethernet

Two 10/100 Ethernet ports with automatic MDI-X (crossover detection) is provided via the single 8-position modular jack labeled LAN. Additional features are available for use over Ethernet, including WebMI, Modbus TCP/IP, EtherNet/IP, SMTP (E-mail), expansion I/O to SmartRail, and more.

Ethernet configuration is done via the Cscape Hardware Configuration. For more information on Ethernet, available features, and protocols, refer to the Ethernet Supplement document (SUP0740).

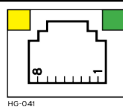
 <p>HG-041</p>	<p><b>Green LED indicates link</b> - when illuminated, data communication is available.</p> <p><b>Yellow LED indicates activity</b> - when flashing, data is in transmission.</p>
---	---

## DIP Switches

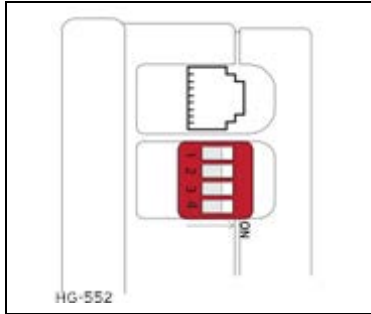
	DIP Switches			
	SWITCH	NAME	FUNCTION	DEFAULT
1	MJ3 RS-485 Termination	ON = Terminated	OFF	
2	MJ3 Duplex	Both ON = Half Both OFF = Full	OFF	
3			OFF	
4	MJ2 RS-485 Termination	ON = Terminated	OFF	

The DIP switches are used to provide a built-in termination to both the MJ1, MJ2 & MJ3 ports if needed. The termination for these ports should only be used if this device is located at either end of the multidrop/ daisy-chained RS-485 network.

## CAN Communications

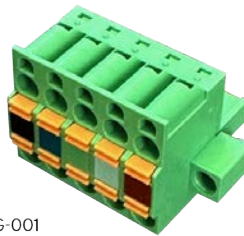

HG-001

CAN Network & Power Port Pin Assignment		
Pin	Signal	Signal Description
1	V-	CAN Ground – Black
2	CN_L	CAN Data Low – Blue
3	SHLD	Shield Ground – None
4	CN_H	CAN Data High – White
5	V+ (NC)	No Connect – Red

- **Solid/Stranded Wire:** 12-24 AWG (2.5-0.2mm<sup>2</sup>).
- **Strip Length:** 0.28" (7mm).
- Locking spring-clamp, two-terminators per conductor.
- **Torque, Terminal Hold-Down Screws:** 4.5 – 7 in•lbs (0.50 – 0.78 N•m).
- V+ pin is not internally connected, the SHLD pin is connected to Earth ground via a 1MΩ resistor and 10 nF capacitor.

## DIMENSIONS & INSTALLATION





**Model 4**

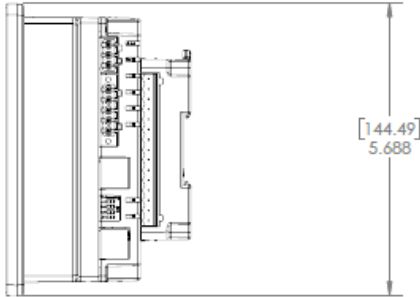
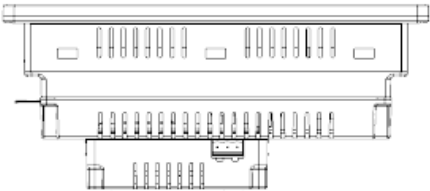
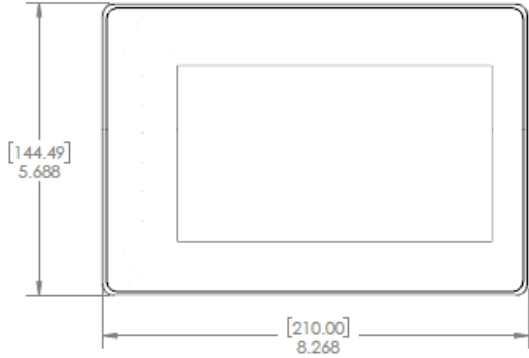
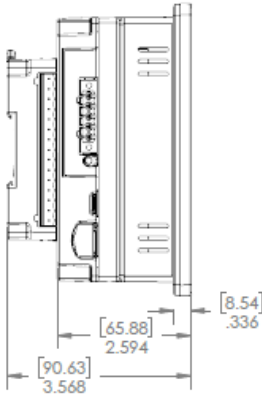
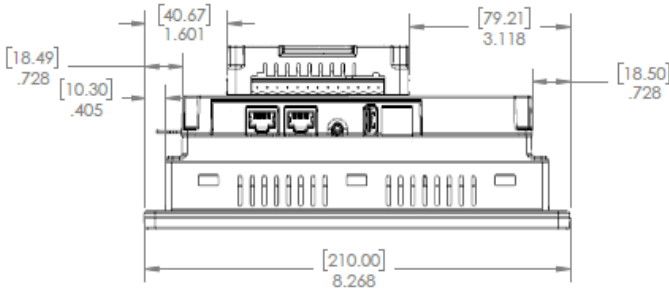



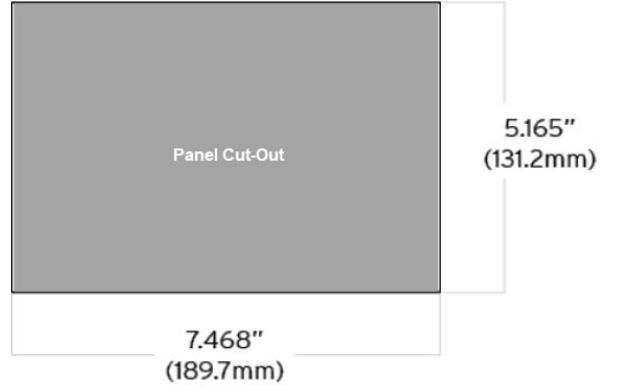

\* ± 1.6mm cutout tolerance

## Installation Information

- The XL7/XL7 Prime utilizes a clip installation method to ensure a robust and watertight seal to the enclosure. Please follow the steps below for the proper installation and operation of the unit.
- This equipment is suitable for Class I, Division 2, Groups A, B, C and D or non-hazardous locations only.
- Digital outputs shall be supplied from the same source as the operator control station.
- Jumpers on connector JP1 shall not be removed or replaced while the circuit is live unless the area is known to be free of ignitable concentrations of flammable gases or vapors.
- **WARNING-** The USB ports are for operational maintenance only. Do not leave permanently connected unless area is known to be non-hazardous.

## Installation Procedure

The OCS utilizes a clip installation method to ensure a robust and watertight seal to the enclosure. Please follow the steps below for the proper installation and operation of the unit.

1. Carefully locate an appropriate place to mount the OCS. Be sure to leave enough room at the top of the unit for insertion and removal of the microSD™ card.
2. Carefully cut the host panel per the diagram, creating an opening with a +1.6mm /-0mm panel cutout tolerance into which the OCS may be installed. If the opening is too large, water may leak into the enclosure, potentially damaging the unit. If the opening is too small, the OCS may not fit through the hole without damage.
3. Remove any burrs and/or sharp edges and ensure the panel is not warped in the cutting process.
4. Remove all Removable Terminals from the OCS. Insert the OCS through the panel cutout (from the front). The gasket must be between the host panel and the OCS.
5. Install and tighten the four mounting clips (provided in the box) until the gasket forms a tight seal.
  - Maximum torque is 0.8 to 1.13N•m, or 7 to 10 in•lbs.
  - Revision 1BB or later hardware should be torqued to 4-7 in•lbs (0.45N•m - 0.79N•m)
6. Reinstall the I/O Removable Terminal Blocks. Connect communications cables to the serial port, USB ports, Ethernet port, and CAN port as required.

## SAFETY & MAINTENANCE

### Warnings

1. To avoid the risk of electric shock or burns, always connect the safety (or earth) ground before making any other connections.
2. To reduce the risk of fire, electrical shock, or physical injury, it is strongly recommended to fuse the voltage measurement inputs. Be sure to locate fuses as close to the source as possible.
3. Replace fuse with the same type and rating to provide protection against risk of fire and shock hazards.
4. In the event of repeated failure, do **NOT** replace the fuse again as repeated failure indicates a defective condition that will **NOT** clear by replacing the fuse.
5. Only qualified electrical personnel familiar with the construction and operation of this equipment and the hazards involved should install, adjust, operate, or service this equipment.
6. Read and understand this manual and other applicable manuals in their entirety before proceeding. Failure to observe this precaution could result in severe bodily injury or loss of life.
7. **WARNING: Battery may explode if mistreated. Do not recharge, disassemble, or dispose of in fire.**
8. **WARNING: EXPLOSION HAZARD - Batteries must only be changed in an area known to be non-hazardous.**
9. **WARNING: Do not disconnect while circuit is live unless area is known to be non-hazardous.**

### FCC Compliance

This device complies with Part 15 of the FCC Rules. Operation is subject to the following two conditions:

1. This device may not cause harmful interference.
2. This device must accept any interference received, including interference that may cause undesired operation.

### Precautions

All applicable codes and standards need to be followed in the installation of this product. Adhere to the following safety precautions whenever any type of connection is made to the module:

1. Connect the safety (earth) ground on the power connector first before making any other connections.
2. When connecting to the electric circuits or pulse-initiating equipment, open their related breakers.
3. Do NOT make connection to live power lines.
4. Make connections to the module first; then connect to the circuit to be monitored.
5. Route power wires in a safe manner in accordance with good practice and local codes.
6. Wear proper personal protective equipment including safety glasses and insulated gloves when making connections to power circuits.
7. Ensure hands, shoes, and floor are dry before making any connection to a power line.
8. Make sure the unit is turned OFF before making connections to terminals.
9. Make sure all circuits are de-energized before making connections.
10. Before each use, inspect all cables for breaks or cracks in the insulation. Replace immediately if defective.
11. Use copper conductors in field wiring only, 60/75°C.
12. Use caution when connecting controllers to PCs via serial or USB. PCs, especially laptops, may use “floating power supplies” that are ungrounded. This could cause a damaging voltage potential between the laptop and controller. Ensure the controller and laptop are grounded for maximum protection. Consider using a USB isolator due to voltage potential differences as a preventative measure.



## Technical Support

North America	Europe
1 (317) 916-4274 1 (877) 665-5666 <a href="http://www.hornerautomation.com">www.hornerautomation.com</a> <a href="mailto:APGUSATechSupport@heapg.com">APGUSATechSupport@heapg.com</a>	+353 (21) 4321-266 <a href="http://www.hornerautomation.eu">www.hornerautomation.eu</a> <a href="mailto:technical.support@horner-apg.com">technical.support@horner-apg.com</a>