

# XL7 Datasheet - Model 6

12 DC In, 12 DC Out, 17-bit Analog In (mA/V/Tc/mV/RTD), 4 – 12-bit Analog Out

MAN1166-21-EN\_XL7\_Mod6



## Part Numbers

Global Part Number	HE-EXL1E6
European Part Number	HEXT371C116

## User Manual and Add-Ons

Find the documents via the [Documentation Search](#).

Part #	Description
MAN0974	XL7 & XL7 Prime User Manual
MAN1142	Rechargeable Battery Manual
HE-BAT019	Rechargeable 3.6V Lithium Battery
HE-XCK	Programming Cables
HE-XDAC	2 channel Analog Output I/O option kit, selectable 0-10V, +/-10V, 4-20mA.
HE-XDAC107	4 channel Analog Output I/O option kit, selectable 0-10V, +/-10V, 4-20mA.
HE-XKIT	Blank I/O Board
HE200MJ2TRM	Adapter, RJ45 (8P8C) male to 8-position terminal strip.
HE-FBD001	Ferrite core for filtering out electrical noise.

## Battery Maintenance

The XL7 has an advanced battery system that uses a rechargeable lithium battery. The battery powers the real time clock when power is removed, and it is needed for register data retention. Manual **MAN0964** via the [Documentation Search](#) for more details on battery replacement.

## Table of Contents

User Manual and Add-Ons .....	1
Battery Maintenance .....	1
<b>TECHNICAL SPECIFICATIONS .....</b>	<b>2</b>
General Specifications .....	2
Control and Logic .....	2
User Interface .....	2
Connectivity .....	2
<b>CONTROLLER OVERVIEW .....</b>	<b>3</b>
Overview of OCS .....	3
Power Wiring .....	3
<b>MODEL 6 SPECIFICATIONS .....</b>	<b>4</b>
Digital DC Input .....	4
Digital DC Outputs .....	4
Analog Inputs .....	5
Analog Outputs .....	5
<b>WIRING: INPUTS AND OUTPUTS .....</b>	<b>6</b>
Analog Inputs Information .....	6
Digital Inputs Information .....	6
Connector Overview .....	7
J1 and J2 Wiring .....	7
J3 Wiring .....	8
Status Registers .....	9
Registers .....	9
<b>COMMUNICATIONS .....</b>	<b>10</b>
Serial Communication .....	10
Ethernet .....	10
Dip Switches .....	10
CAN Communications .....	10
<b>DIMENSIONS &amp; INSTALLATION .....</b>	<b>11</b>
XL7 & XL7 Prime .....	11
Installation Information .....	11
Installation Procedure .....	11
<b>SAFETY &amp; MAINTENANCE .....</b>	<b>12</b>
Warnings .....	12
FCC Compliance .....	12
Technical Support .....	12
Precautions .....	12

# TECHNICAL SPECIFICATIONS

## General Specifications

Required Power (Steady State)	170mA @ 24VDC
Heater Option	250mA with heater* (24VDC)
Required Power (Inrush)	25A for < 1ms @ 24VDC, DC switched
Primary Power Range	10 - 30VDC
Max. Current	1100mA, Class 2
Relative Humidity	5 to 95% non-condensing
Typical Power Backlight 100%	4.848W @ 24VDC
Power Backlight 50%	3.792WW @ 24VDC
Power Backlight OFF	3.408W @ 24VDC
Clock Accuracy	+ / - 20 ppm maximum at 25°C (+/- 1 min/month)
Real Time Clock	Battery Backed, Rechargeable Lithium
Operating Air Temp	-10°C to +60°C
Storage Temp	-20°C to +60°C
Weight	2 lbs (907g)
Altitude	Up to 2000m
Rated Pollution Degree	Evaluated for Pollution Degree 2 Rating
Certifications (UL/CE)	<a href="#">North America</a> or <a href="#">Europe</a>
Enclosure Type	1, 3R, 4, 4X, 12, 12K & 13

\*Heater Option (Model # plus "-22")

## Control and Logic

Control Lang. Support	Register-Based Advanced Ladder Logic; Variable-Based Advanced Ladder IEC 61131-3 Languages
Logic Program Size	2MB, maximum
Scan Rate	.013ms/kB
Digital Inputs	2048
Digital Outputs	2048
Analog Inputs	512
Analog Outputs	512
Gen. Purpose Registers	50,000 (words) Retentive 16,384 (bits) Retentive 16,384 (bits) Non-retentive

## User Interface

Display Type	7" TFT Color
Screen Brightness	800cd/m <sup>2</sup> (nits)
Resolution	QVGA (800 x 480)
Color	16-bit (65,535)
Screen Memory	17MB
User-Program. Screens	1023 max pages; 1023 objects per page
Backlight	LED - 50,000 hour life

## Connectivity

Serial Ports	1 RS-232 & 1 RS-485 on first Modular Jack (MJ1/2); 1 RS-232 or 1 RS-485 on second Modular Jack
USB mini-B	USB 2.0 (480MHz) Programming & Data Access
USB A (500mA max)	USB 2.0 (480MHz) for USB flash drives (2TB)
CAN Port Isolated 1kV	2 x Remote I/O, Peer-to-peer Comms, Cscape
CAN Protocols	CsCAN, CANopen, DeviceNet, J1939
Ethernet	2 x 10/100 Mb (Auto-MDX)
Ethernet Protocols	TCP/IP, Modbus TCP, FTP, SMTP, EGD, ICMP, ASCII, Cscape, Ethernet IP
Remote I/O	SmartRail, SmartStix, SmartBlock, SmartMod
Removable Memory	microSD, SDHC, SDXC IN FAT32 format, support for 32GB max. Application Updates, Data-logging

# CONTROLLER OVERVIEW

## Overview of OCS

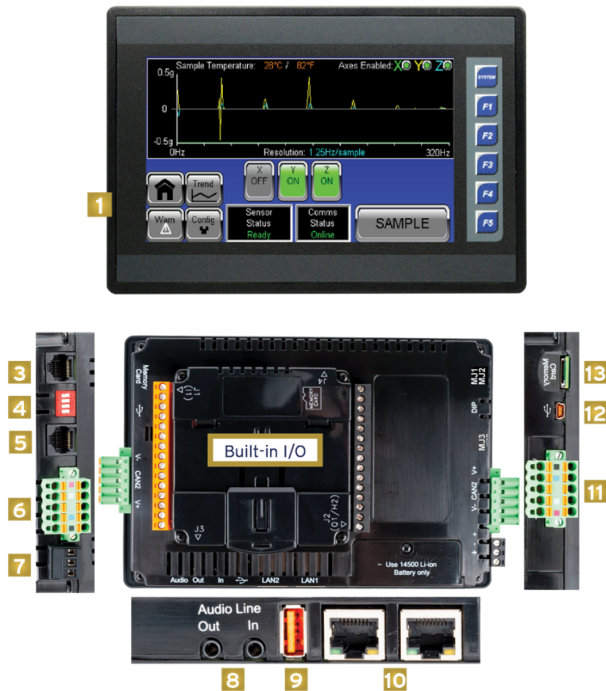

1. Touchscreen
2. Function Keys
3. MJ1: RS232 / MJ2: 1/2 Duplex RS485
4. Dip Switches
5. MJ3: RS-232/485 Serial Port
6. CAN1 Port
7. PWR: 10-30VDC In
8. Audio In & Out Ports
9. USB 2.0 "A": Flash Drive; See Precaution #12 about USB and grounding.
10. LAN 1 & 2 Ports\*
11. CAN2 Port
12. USB mini "B": Programming
13. microSD: Data Storage

## Power Wiring

**NOTE:** The Primary Power Range is 10VDC to 30VDC.

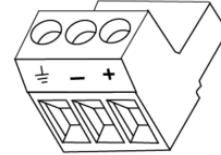

Primary Power Port Pins		
PIN	Signal	Description
1	Ground	Frame Ground
2	DC-	Input Power Supply Ground
3	DC+	Input Power Supply Voltage

## DC Input / Frame

- Solid/Stranded Wire: 12-24 awg (2.5-0.2mm)
- Strip length: 0.28" (7mm)
- Torque, Terminal Hold-Down Screws: 4.5 – 7 in-lbs (0.50 – 0.78 N-m)
- DC- is internally connected to I/O V-, but is isolated from CAN V-. A Class 2 power supply must be used.

## Power Up

1. **OPTION:** Attach ferrite core with a minimum of two turns of the DC+ and DC- signals from the DC supply that is powering the controllers.



2. Connect to earth ground.
3. Apply recommended power.

## MODEL 6 SPECIFICATIONS

### Digital DC Input

Inputs per Module	12 Including 4 Configurable HSC Inputs	
Commons per Module	1	
Input Voltage Range	12VDC / 24VDC	
Absolute Max. Voltage	30VDC Max.	
Input Impedance	10k $\Omega$	
Input Current	Positive Logic	Negative Logic
Upper Threshold	0.8mA	-1.6mA
Lower Threshold	0.3mA	-2.1mA
Max. Upper Threshold	8VDC	
Min. Lower Threshold	3VDC	
OFF to ON Response	1ms	
ON to OFF Response	1ms	
Galvanic Isolation	None	
Logic Polarity	Selectable in Cscope	
I/O Indication	9 (IN 9-12)	
Connector Type	3.5mm Pluggable Cage Clamp Connector	
High Speed Counter Max Freq	1MHz	

### Digital DC Outputs

Outputs per Module	16 Including 2 Configurable PWM Outputs	
Commons per Module	1	
Output Type	Sourcing / 10k $\Omega$ Pull-Down	
Output Frequency	500kHz	
Absolute Max. Voltage	28VDC Max.	
Output Protection	Short Circuit	
Max. Output Current / Point	0.5A	
Max. Total Current	4A Continuous	
Max. Output Supply Voltage	30VDC	
Min. Output Supply Voltage	10VDC	
Max. Voltage Drop at Rated Current	0.25VDC	
Max. Inrush Current	650mA per Channel	
Min. Load	None	
OFF to ON Response	1ms	
ON to OFF Response	1ms	
Output Characteristics	Current Sourcing (Pos. Logic)	
PWM Out	$\approx$ 5kHz	
Rise Time	50 - 115 $\mu$ s	
Fall Time	8-20 $\mu$ s	

## Analog Inputs

Number of Channels	6		
Input Ranges (Selectable)	0-20mA; 4-20mA DC; 0-60mV; 0-10VDC; <b>T/C (Ungrounded): J, K, N, T, E, R, S, B</b> <b>RTD: PT100, PT1000</b>		
%AI Full Scale	<b>10V, 20MA, 100mV:</b> 32,000 counts full scale <b>RTD/ TC:</b> 20 counts/ °C		
Nominal Resolution	17 Bits		
Absolute Max. Input Voltage	-0.5 to -12VDC (+/- 30VDC)		
Input Impedance (Clamped @ -0.5 to 10.23VDC)	T/C / RTD / mV > 2MΩ mA: 15Ω + 1.5V / V: 1.1MΩ		
Max Over Current	35mA		
Galvanic Isolation	None		
Conversion Speed	Min. All Channels Converted in app. < 250ms or 41ms per channel enable		
Sensor Range and Accuracy	<b>Input Type:</b>	<b>Range:</b>	<b>Accuracy:</b>
	TC J (Ungrounded)	-120 to 1000°C / -184 to 1832°F	+/- 0.2% of full scale +/- 1°C
	TC K (Ungrounded)	-130 to 1372°C / -202 to 2501.6°F	+/- 0.2% of full scale +/- 1°C
	TC T (Ungrounded)	-130 to 400°C / -202 to 752°F	+/- 0.2% of full scale +/- 1°C
	TC E (Ungrounded)	-130 to 780°C / -202 to 1436°F	+/- 0.2% of full scale +/- 1°C
	TC N (Ungrounded)	-130 to 1300°C / -202 to 2372°F	+/- 0.2% of full scale +/- 1°C
	TC R, S (Ungrounded)	20 to 1768°C / 68 to 3214.4°F	+/- 0.2% of full scale +/- 3°C
	TC B (Ungrounded)	500 to 1820°C / 212 to 3308°F Functions below 500°C with reduced accuracy.	+/- 0.2% of full scale +/- 3°C
	PT100/1000	-200 to 850°C / -328 to 1562°F	+/- 0.15% of full scale
	0-20mA	0-20mA	+/- 0.15% of full scale
	0-60mV	0-60mV	+/- 0.15% of full scale
	0-10V	0-10V	+/- 0.15% of full scale

## Analog Outputs

Number of Channels	4
Output Ranges	0-10VDC, 0-20mA, 4-20mA
Nominal Resolution	12 Bits
Max. Error at 25°C (Excluding Zero)	0-20mA 0.1% of full scale 0-10V 0.1 % of full scale
Maximum Loop Voltage	27V
Response Time	One Update per program logic scan
Minimum Resistance Load	500Ω
Conversion Speed	Min. All Channels Once per Scan
Galvanic Isolation	None
Temperature Drift Error	20mA.....0.000143%/°C 0 - 10V.....0.000151%/°C

## WIRING: INPUTS AND OUTPUTS

### Analog Inputs Information

Raw input values for channels 1-4 are found in the registers as Integer- type data with a range from 0 – 32000. Analog inputs may be filtered digitally with the Filter Constant found in the Cscape Hardware Configuration for Analog Inputs. Valid filter values are 0-7 and act according to the following chart:

Data Values	
<b>Input Mode:</b>	<b>Data Format, 12-bit INT:</b>
0-20mA, 4-20mA	0-32000
0-41V	0-32000
T/C & RTD	°C or °F may be selected in the Hardware Configuration section in Cscape. The raw value is an integer, so the user should divide by 10.

### Digital Inputs Information

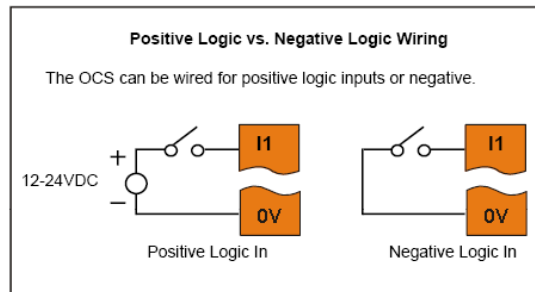

Digital inputs may be wired in either a Positive Logic or Negative Logic fashion as shown. The setting in the Cscape Hardware Configuration for the Digital Inputs must match the wiring used in order for the correct input states to be registered. When used as a normal input and not for high speed functions, the state of the input is reflected in registers %I1 – %I12. Digital inputs may alternately be specified for use with High Speed Counter functions, also found in the Hardware Configuration for Digital Inputs. Refer to the User Manual via the [Documentation Search](#) for more details.

# Connector Overview

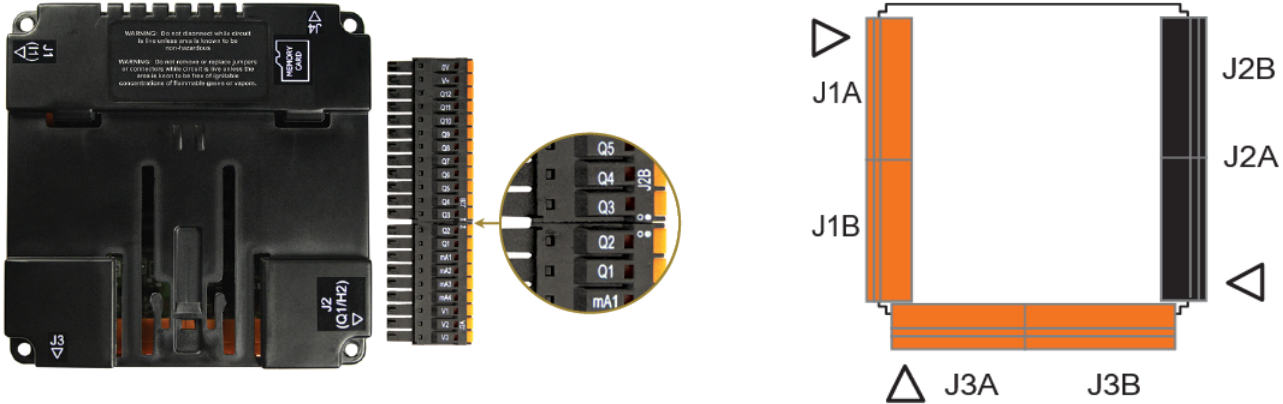

For ease of operability, the high density terminals are divided into more manageable pairs of connectors (J1A + J1B, J2A + J2B, J3A + J3B). To ensure proper installation, connector symbols must match.

## J1 and J2 Wiring

### J1 Wiring

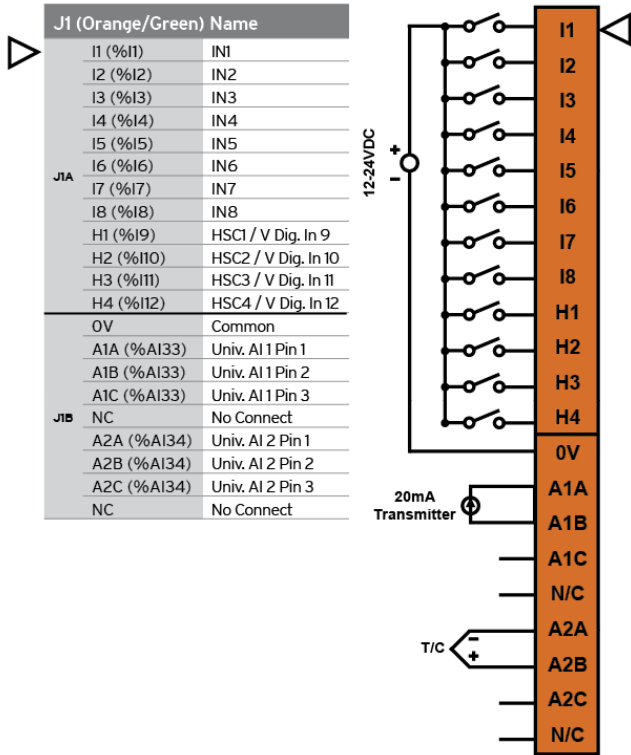

### J2 Wiring

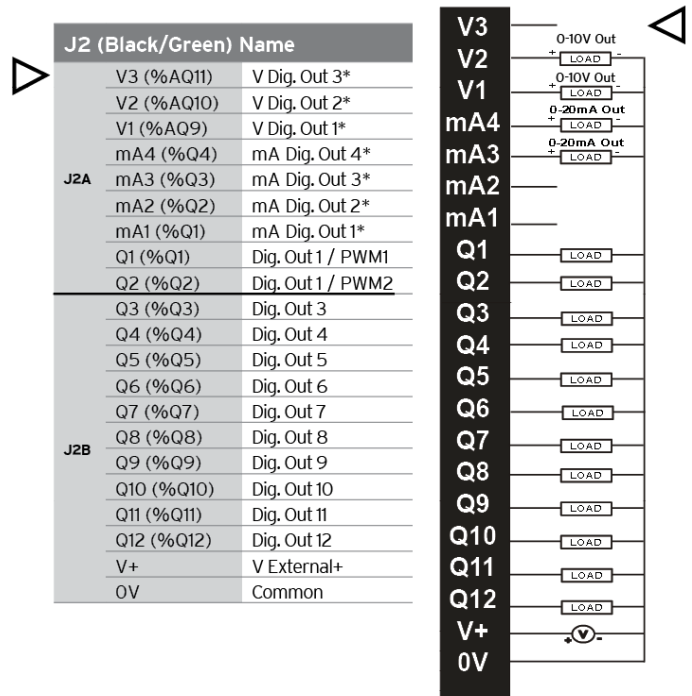



# J3 Wiring

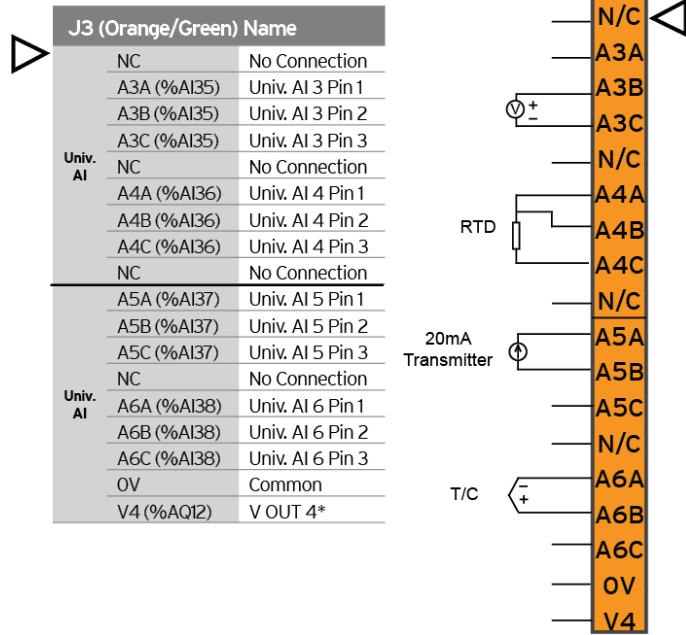

**NOTE:** \* Both mA & V outputs are active for each output channel, however, only the configured output type is calibrated (maximum 4 channels simultaneously).

## J3 Universal Wiring & Wiring Details

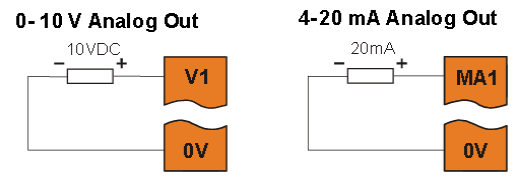
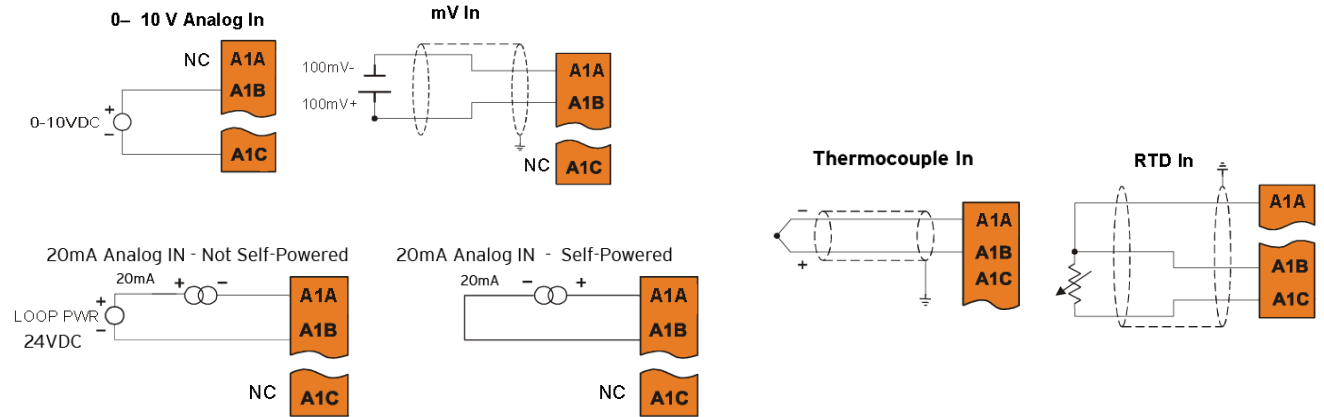

### Wiring Details

**Solid/Stranded Wire:** 12-24 awg (2.5-0.2mm<sup>2</sup>).  
**Strip Length:** 0.28" (7mm).  
**Torque, Terminal Hold-Down Screws:** 4.5 – 7 in-lbs (0.50 – 0.78 N-m).



## Status Registers

Selectable Range	Description							
%Rx*	Bit-wise status register enable: Set %Rx.1 - %Rx.9 high to enable for registers %R(x+1) to %R(x+9).							
%R(x+1)	Firmware version							
%R(x+2)	Watchdog count - cleared on power-up.							
%R(x+3)	Status Bits:				16...4	3	2	1
					Reserved	Normal	Config	Calibration
%R(x+4)	Scan rate of the 106 board (average) in units of 100 $\mu$ s.							
%R(x+5)	Scan rate of the 106 board (max) in units of 100 $\mu$ s.							
%R(x+6)	<b>Channel Status: Channel 2</b>				<b>Channel 1</b>			
	8	7	6	5	4	3	2	1
	Open RTD	Out of Limits	Shorted RTD	Open Sensor	Open RTD	Out of Limits	Shorted RTD	Open Sensor
%R(x+7)	<b>Channel Status: Channel 4</b>				<b>Channel 3</b>			
	8	7	6	5	4	3	2	1
	Open RTD	Out of Limits	Shorted RTD	Open Sensor	Open RTD	Out of Limits	Shorted RTD	Open Sensor
%R(x+8)	<b>Channel Status: Channel 6</b>				<b>Channel 5</b>			
	8	7	6	5	4	3	2	1
	Open RTD	Out of Limits	Shorted RTD	Open Sensor	Open RTD	Out of Limits	Shorted RTD	Open Sensor
%R(x+9...14)	Reserved							

\*Example: %Rx= %R500, %R(x+1) = %R501, %R(x+2) = %R502, ...

## Registers

The I/O is mapped into OCS Register space, in three separate areas: Digital/Analog I/O, High-Speed Counter I/O, and High-Speed Output I/O. Digital/Analog I/O location is fixed starting at 1, but the high-speed counter and high-speed output references may be mapped to any open register location.

Digital and Analog I/O Functions Registers	
Digital Inputs	%I1-12
Reserved	%I13-31
ESCP Alarm	%I32
Digital Outputs	%Q1-12
Reserved	%Q13-24
Analog Inputs	%AI33-38
Reserved	%AI1-32
Analog Outputs	%AQ9-12
Reserved	%AQ1-8

# COMMUNICATIONS

## Serial Communication

### MJ1/2 Serial Ports

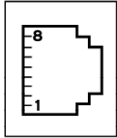

MJ1/2 Independent Serial Ports

**MJ1:** RS-232 w/Full Handshaking

**MJ2:** RS-485 Half-Duplex

PIN	MJ1 PINS		MJ2 PINS	
	SIGNAL	DIRECTION	SIGNAL	DIRECTION
8	TXD	OUT	--	--
7	RXD	IN	--	--
6	0V	GROUND	0V	GROUND
5	+5V @ 60mA	OUT	+5V @ 60mA	OUT
4	RTS	OUT	--	--
3	CTS	IN	--	--
2	--	--	RX- / TX-	IN / OUT
1	--	--	RX+ / TX+	IN / OUT

### MJ3 Serial Port

2 Multiplexed Serial Ports on One Modular Jack (8 posn)

PIN	MJ3 PINS	
	SIGNAL	DIRECTION
8	TXD RS232	OUT
7	RXD RS232	IN
6	0V	GROUND
5	+5V @ 60mA	OUT
4	TX- RS485	OUT
3	TX+ RS485	OUT
2	RX- RS485	IN
1	RX+ RS485-	IN

**NOTE:** Attach optional [ferrite core](#) with a minimum of two turns of serial cable.

## Ethernet

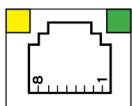

**Green LED indicates link** - when illuminated, data communication is available.  
**Yellow LED indicates activity** - when flashing, data is in transmission.

## Dip Switches

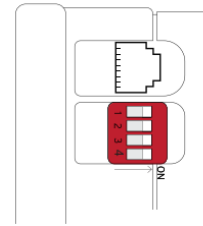

DIP Switches			
PIN	NAME	FUNCTION	DEFAULT
1	MJ3 RS-485 Termination	ON = Terminated	OFF
2	MJ3 Duplex	ON = Half	OFF
3		OFF = Full	OFF
4	MJ2 RS485 Termination	ON = Terminated	OFF

The DIP switches are used to provide a built-in termination to both the MJ1, MJ2 & MJ3 ports if needed. The termination for these ports should only be used if this device is located at either end of the multidrop/ daisy-chained RS-485 network.

## CAN Communications

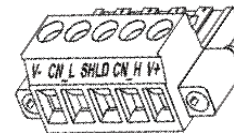

CAN Pin Assignments		
PIN	SIGNAL	DESCRIPTION
1	V-	CAN Ground – Black
2	CN_L	CAN Data Low – Blue
3	SHLD	Shield Ground – None
4	CN_H	CAN Data High – White
5	V+ (NC)	No Connect – Red

- **Solid/Stranded Wire:** 12-24 awg (2.5-0.2mm).
- **Strip Length:** 0.28" (7mm).
- Locking spring-clamp, two-terminators per conductor.
- **Torque, Terminal Hold-Down Screws:** 4.5 – 7 in-lbs (0.50 – 0.78 N-m).
- V+ pin is not internally connected, the SHLD pin is connected to Earth ground via a 1MΩ resistor and 10 nF capacitor.

## DIMENSIONS & INSTALLATION

### XL7 & XL7 Prime

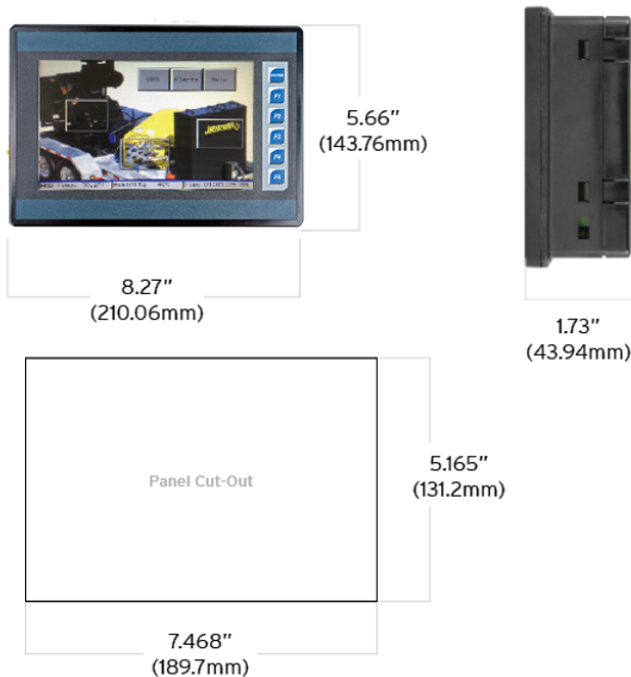

\* +/- 1.6mm cutout tolerance

### Installation Information

- The XL7/XL7 Prime utilizes a clip installation method to ensure a robust and watertight seal to the enclosure. Please follow the steps below for the proper installation and operation of the unit.
- This equipment is suitable for Class I, Division 2, Groups A, B, C and D or non-hazardous locations only.
- Digital outputs shall be supplied from the same source as the operator control station.
- Jumpers on connector JP1 shall not be removed or replaced while the circuit is live unless the area is known to be free of ignitable concentrations of flammable gases or vapors.
- **WARNING-** The USB ports are for operational maintenance only. Do not leave permanently connected unless area is known to be non-hazardous.

### Installation Procedure

The OCS utilizes a clip installation method to ensure a robust and watertight seal to the enclosure. Please follow the steps below for the proper installation and operation of the unit.

1. Carefully locate an appropriate place to mount the OCS. Be sure to leave enough room at the top of the unit for insertion and removal of the microSD™ card.
2. Carefully cut the host panel per the diagram, creating a 131.2mm x 189.7mm with a +1.6mm /-0mm panel cutout tolerance, opening into which the OCS may be installed. If the opening is too large, water may leak into the enclosure, potentially damaging the unit. If the opening is too small, the OCS may not fit through the hole without damage.
3. Remove any burrs and or sharp edges and ensure the panel is not warped in the cutting process.
4. Remove all Removable Terminals from the OCS. Insert the OCS through the panel cutout (from the front). The gasket must be between the host panel and the OCS.
5. Install and tighten the four mounting clips (provided in the box) until the gasket forms a tight seal **NOTE:** Max torque is 0.8 to 1.13Nm, or 7 to 10 in-lbs.
6. Reinstall the I/O Removable Terminal Blocks. Connect communications cables to the serial port, USB ports, Ethernet port, and CAN port as required.

# SAFETY & MAINTENANCE

## Warnings

1. To avoid the risk of electric shock or burns, always connect the safety (or earth) ground before making any other connections.
2. To reduce the risk of fire, electrical shock, or physical injury, it is strongly recommended to fuse the voltage measurement inputs. Be sure to locate fuses as close to the source as possible.
3. Replace fuse with the same type and rating to provide protection against risk of fire and shock hazards.
4. In the event of repeated failure, do NOT replace the fuse again as repeated failure indicates a defective condition that will NOT clear by replacing the fuse.
5. Only qualified electrical personnel familiar with the construction and operation of this equipment and the hazards involved should install, adjust, operate, or service this equipment.
6. Read and understand this manual and other applicable manuals in their entirety before proceeding. Failure to observe this precaution could result in severe bodily injury or loss of life.
7. **WARNING** - Battery may explode if mistreated. Do not recharge, disassemble, or dispose of in fire.
8. **WARNING - EXPLOSION HAZARD** - Batteries must only be changed in an area known to be non-hazardous.
9. **WARNING** - Do not disconnect while circuit is live unless are is know to be non-hazardous.

## FCC Compliance

This device complies with Part 15 of the FCC Rules. Operation is subject to the following

two conditions:

1. This device may not cause harmful interference.
2. This device must accept any interference received, including interference that may cause undesired operation.

## Technical Support

### North America

1 (317) 916-4274

(877) 665-5666

[www.hornerautomation.com](http://www.hornerautomation.com)

[techsppt@heapg.com](mailto:techsppt@heapg.com)

### Europe

+353 (21) 4321-266

[www.hornerautomation.eu](http://www.hornerautomation.eu)

[technical.support@horner-apg.com](mailto:technical.support@horner-apg.com)

## Precautions

All applicable codes and standards need to be followed in the installation of this product. Adhere to the following safety precautions whenever any type of connection is made to the module:

1. Connect the safety (earth) ground on the power connector first before making any
2. other connections.
3. When connecting to the electric circuits or pulse-initiating equipment, open their
4. related breakers.
5. Do NOT make connection to live power lines.
6. Make connections to the module first; then connect to the circuit to be monitored.
7. Route power wires in a safe manner in accordance with good practice and local codes.
8. Wear proper personal protective equipment including safety glasses and insulated gloves when making connections to power circuits.
9. Ensure hands, shoes, and floor are dry before making any connection to a power line.
10. Make sure the unit is turned OFF before making connection to terminals.
11. Make sure all circuits are de-energized before making connections.
12. Before each use, inspect all cables for breaks or cracks in the insulation. Replace
13. immediately if defective.
14. Use copper conductors in Field Wiring only, 60/75°C.
15. Use caution when connecting controllers to PCs via serial or USB. PCs, especially laptops, may use "floating power supplies" that are ungrounded. This could cause a damaging voltage potential between the laptop and controller. Ensure the controller and laptop are grounded for maximum protection. Consider using a USB isolator due to voltage potential differences as a preventative measure.